



PAUL R. LEPAGE
GOVERNOR

STATE OF MAINE
MAINE DEPARTMENT OF AGRICULTURE, CONSERVATION AND FORESTRY
BOARD OF PESTICIDES CONTROL
28 STATE HOUSE STATION
AUGUSTA, MAINE 04333-0028

WALTER E. WHITCOMB
COMMISSIONER
HENRY S. JENNINGS
DIRECTOR

BOARD OF PESTICIDES CONTROL

April 24, 2015

AMHI Complex, 90 Blossom Lane, Deering Building, Room 319, Augusta, Maine

AGENDA

8:30 AM

1. Introductions of Board and Staff
2. Minutes of the December 5, 2014 and January 14, 2015 Board Meetings

Presentation By: Henry Jennings
Director

Action Needed: Amend and/or Approve

3. Section 18 Emergency Registration Renewal Request for HopGuard to Control *Varroa* Mites in Honey Bee Colonies

The Division of Animal and Plant Health, in the Maine Department of Agriculture, Conservation and Forestry, is requesting that the Board recertify the petition to EPA for a FIFRA Section 18 specific exemption for use of HopGuard (potassium salt of hop beta acids) to control *Varroa* mites in managed bee colonies. State Apiarist Tony Jadczyk is seeking approval to continue use of this product, which has provided consistent control against *Varroa* mites during the last three seasons, and is an important alternative in resistance management and organic honey production. He points out that a healthy bee keeping industry is needed to support Maine agriculture, and that this product is essential to honey production and commercial bee operators. The request is supported by the registrant, BetaTec Hop Products, a wholly owned subsidiary of John I. Haas, Inc.

Presentation by: Henry Jennings
Director

Action Needed: Approve/Deny Request to Petition EPA for a Section 18 Specific Exemption Registration for HopGuard for Use with Bees.

4. Final Adoption of Amendments to Chapters 22 and 28

On July 16, 2014, a Notice of Agency Rulemaking Proposal was published in Maine's daily newspapers, opening the comment period on the proposed amendments to Chapters 20, 22, 28, 31, 32, 33 and 41. A public hearing was held on August 8, 2014, at the Deering Building. The Board reviewed the

rulemaking record on September 12, 2014, addressed the comments and provided direction to the staff on appropriate revisions to the proposals. On October 24, 2014 the Board adopted amendments for Chapters 20, 31, 32, 33 and 41 and provisionally adopted amendments to Chapters 22 and 28. The Joint Standing Committee on Agriculture, Conservation and Forestry held public hearings on February 24, 2015 and voted out-to-pass on two resolves on February 27, 2014 and they were enacted as emergency legislation and became law without the governor's signature on March 29, 2015. The Board has 60 days from the effective dates of the resolves to finally adopt the rules.

Presentation by: Henry Jennings
Director

Action Needed: Final Adoption of the Rule, Basis Statement, Rulemaking Statement of Impact on Small Business, and Response to Comments for Chapters 22 and 28

5. Development of Guidelines for the Board Related to the Issuance of Variance Permits for Spraying Railroads Adjacent to Surface Waters

At the May 16, 2014, meeting, the Board granted a one-year variance from Section 6 of Chapter 29 to Asplundh Tree Expert Company—Railroad Division to make broadcast herbicide applications less than 25 feet from surface water. At that time, the Board also directed the staff to develop guidelines/criteria for issuance of railroad variances prior to next season. Robert Moosmann of MDOT has developed some draft guidelines and the staff has been researching the Board concerns. The staff will present its findings and seek feedback from the Board.

Presentation By: Henry Jennings
Director

Action Needed: Establish Criteria for Granting Railroad Variances

6. Review of Interim Guidelines for Forest Pesticide Applications Intended to Prevent Discharges of Pesticides to Waters of the State

On June 27, 2012, the Board approved *Interim Guidelines for Forest Pesticide Applications* with the statement: "These guidelines were not developed for and are not intended to serve as standards for permitting purposes." At that time there was not a general pesticide permit to cover pesticide applications made over or near water and these guidelines were intended to help prevent discharges of pesticides. In April, 2015, the Maine Department of Environmental Protection finalized a general permit for aerial application of forest pesticides and referenced BPC Best Management Practices. Additionally, at the Joint Standing Committee on Agriculture, Conservation and Forestry work session for LD 817, An Act Regarding Aerial Pesticide Spray Projects, there was discussion about adding references to technological advances for aerial spraying. Should anything be added to improve this document? Should the condition be removed given that the document has been referenced in a state permit?

Presentation By: Henry Jennings
Director

Action Needed: Provide Guidance to the Staff

7. Consideration of a Board Policy Regarding Application of Pesticides to Unoccupied Hotel Rooms and Apartments

At the December 5, 2014 meeting, the Board had a discussion regarding pesticide use in hotel rooms and unoccupied apartments. State statutes define pesticide applications made to property open to use by the

public as “custom applications” which may only be conducted by a licensed commercial applicator. Section 2 (P) (2) of Chapter 10 provides the exemption, “where the public has not been permitted upon the property at any time within seven days of when the property received a pesticide application.” The Board expressed concerns about the higher risk of exposure from indoor applications and came to a consensus that the term “property” means the entire building when it involves residential apartments and lodging places. The staff has drafted a policy attempting to capture the Board’s intent. The Board will review the draft and determine whether it needs to be amended.

Presentation By: Gary Fish
Manager of Pesticide Programs

Action Needed: Review/Approve Draft Policy

8. Interpretation of CMR 01-026, Chapter 10, Section 2 (P) (2), Definition of Property Open to Use by the Public as Regards Outdoor Applications

At the December 5, 2014, meeting, the Board had a discussion about the definition of “property open to use by the public,” which state statutes defines as commercial applications requiring a licensed applicator. Section 2 (P) (2) of Chapter 10 provides the exemption, “where the public has not been permitted upon the property at any time within seven days of when the property received a pesticide application.” During that discussion it was noted that this exemption has been used most commonly by land trusts to treat for invasive plants where they post and indicate the area (but not the entire “property”) is temporarily closed to the public. The Board tabled the issue until Curtis Bohlen was present as he has experience working with land trusts. The staff seeks guidance from the Board on whether this is the appropriate interpretation of the rule.

Presentation By: Gary Fish
Manager of Pesticide Programs

Action Needed: Provide Guidance on Interpretation of the Chapter 10 Definition

9. Consideration of a Consent Agreement with Dan Brown of Blue Hill

On June 3, 1998, the Board amended its Enforcement Protocol to authorize staff to work with the Attorney General and negotiate consent agreements in advance on matters not involving substantial threats to the environment or public health. This procedure was designed for cases where there is no dispute of material facts or law, and the violator admits to the violation and acknowledges a willingness to pay a fine to resolve the matter. This case involves the purchase of a Restricted Use Pesticide (Gramoxone) by an unlicensed applicator.

Presentation By: Raymond Connors
Manager of Compliance

Action Needed: Approve/Disapprove the Consent Agreement Negotiated by Staff

10. Consideration of a Consent Agreement with Lucas Tree Experts Company of Portland

On June 3, 1998, the Board amended its Enforcement Protocol to authorize staff to work with the Attorney General and negotiate consent agreements in advance on matters not involving substantial threats to the environment or public health. This procedure was designed for cases where there is no dispute of material facts or law, and the violator admits to the violation and acknowledges a willingness to pay a fine to resolve the matter. This case involved an application of lawn care pesticides within 250 feet of a property listed on the Maine Pesticide Notification Registry. The registry member did not receive advance notice.

Presentation By: Raymond Connors
Manager of Compliance

Action Needed: Approve/Disapprove the Consent Agreement Negotiated by Staff

11. Consideration of a Consent Agreement with Theriault Lawn Care Inc. of Caribou

On June 3, 1998, the Board amended its Enforcement Protocol to authorize staff to work with the Attorney General and negotiate consent agreements in advance on matters not involving substantial threats to the environment or public health. This procedure was designed for cases where there is no dispute of material facts or law, and the violator admits to the violation and acknowledges a willingness to pay a fine to resolve the matter. This case involved a company making commercial pesticide applications expired licenses over multiple years. In addition, the company's applications records were incomplete and a pesticide was applied to a site not listed on the label.

Presentation By: Raymond Connors
Manager of Compliance

Action Needed: Approve/Disapprove the Consent Agreement Negotiated by Staff

12. Other Old or New Business

a. Legislation

- LD 708, An Act To Limit the Use of Pesticides on School Grounds
- LD 817, An Act Regarding Aerial Pesticide Spray Projects
- LD 1098, An Act To Protect Children from Exposure to Pesticides
- LD 1099, An Act To Establish a Fund for the Operations and Outreach Activities of the University of Maine Cooperative Extension Animal and Plant Disease and Insect Control Laboratory
- LD 1105, An Act To Protect Populations of Bees and Other Pollinators
- LD 1106, An Act To Compensate Beekeepers for Hive Losses

b. NPDES update (link for *General Permit for the Discharge of Pesticides* on BPC home page)

c. 2015 ERAC Report to the Legislature

d. CMP Drift Management Plan

e. Variance Permit to The Woodlands Club

f. Variance Permit to Vegetation Control Service, Inc. for control of invasive plants in Biddeford Pool

g. Variance Permit to Vegetation Control Service, Inc. for the transmission line at the Kibby Wind Power Project

h. Letter to Health Care Facilities

i. Other?

13. Schedule of Future Meetings

June 5, 2015 is a tentative Board meeting dates. The Board will decide whether to change and/or add dates.

- Tentative plan for field trip/Board meeting August 27-28 (Thanks to Nancy McBrady for her hard work on this)
 - Leave Augusta Thursday morning, August 27, arrive in Jonesboro around noon. Have lunch and tour the Blueberry Hill Farm Experimental Station.
 - Proceed to Wyman's of Maine, Deblois for a tour of the processing facility and fields.

- Proceed to Machias for dinner/overnight. Listening session in the evening?
 - Board Meeting Friday, August 28 at University of Maine Machias. Listening session before meeting?
 - Eat lunch.
 - Return to Augusta.
- Adjustments and/or Additional Dates?

14. Adjourn

NOTES

- The Board Meeting Agenda and most supporting documents are posted one week before the meeting on the Board website at www.thinkfirstspraylast.org.
- Any person wishing to receive notices and agendas for meetings of the Board, Medical Advisory Committee, or Environmental Risk Advisory Committee must submit a request in writing to the Board's office. Any person with technical expertise who would like to volunteer for service on either committee is invited to submit their resume for future consideration.
- On November 16, 2007, the Board adopted the following policy for submission and distribution of comments and information when conducting routine business (product registration, variances, enforcement actions, etc.):
 - *For regular, non-rulemaking business*, the Board will accept pesticide-related letters, reports, and articles. Reports and articles must be from peer-reviewed journals. E-mail, hard copy, or fax should be sent to the attention of Anne Chamberlain, at the Board's office or anne.chamberlain@maine.gov. In order for the Board to receive this information in time for distribution and consideration at its next meeting, all communications must be received by 8:00 AM, three days prior to the Board meeting date (e.g., if the meeting is on a Friday, the deadline would be Tuesday at 8:00 AM). Any information received after the deadline will be held over for the next meeting.
- During rulemaking, when proposing new or amending old regulations, the Board is subject to the requirements of the APA (Administrative Procedures Act), and comments must be taken according to the rules established by the Legislature.



PAUL R. LEPAGE
GOVERNOR

STATE OF MAINE
MAINE DEPARTMENT OF AGRICULTURE, CONSERVATION AND FORESTRY
BOARD OF PESTICIDES CONTROL
28 STATE HOUSE STATION
AUGUSTA, MAINE 04333-0028

WALTER E. WHITCOMB
COMMISSIONER
HENRY S. JENNINGS
DIRECTOR

BOARD OF PESTICIDES CONTROL

December 5, 2014

AMHI Complex, 90 Blossom Lane, Deering Building, Room 319, Augusta, Maine

MINUTES

8:30 AM

Present: Eckert, Flewelling, Granger, Jemison, Morrill, Stevenson

1. Introductions of Board and Staff

- The Board and Staff introduced themselves.
- Staff Present: Chamberlain, Connors, Fish, Jennings, Patterson, Tomlinson

2. Minutes of the October 24, 2014, Board Meeting

Presentation By: Henry Jennings
Director

Action Needed: Amend and/or Approve

- **Granger/Eckert: Moved and seconded to approve the October minutes as written.**
- **In favor: Unanimous**

3. Consideration of a Board Policy Covering Acceptable Notification Methods for Commercial Pesticide Applications under Category 6B to Trails and Sidewalks

At the October 24, 2014, meeting, the Board provisionally adopted amendments to Chapter 28, Notification Provisions for Outdoor Pesticide Applications. These amendments will require commercial applicators controlling vegetation on sidewalks or trails under commercial licensing category 6B to provide notice consistent with Board policy. Since these amendments require legislative approval, it may be prudent for the Board to adopt the policy prior to the legislative review process in case there are questions about the Board's intentions. The Board will review the staff's draft and brainstorm ideas about appropriate notification procedures for trails and sidewalks.

Presentation By: Henry Jennings
Director

Action Needed: Review/Approve Draft Policy

- Jennings noted that Morrill had suggested a policy should be adopted sooner rather than later so that when the rule amendment comes up in the Legislative Committee the Board's intent would be clear. The draft is an attempt to capture the Board's stated views from the previous

meeting. Concern was expressed about discouraging property owners from allowing the public to use trails on private properties. Definitions used in the draft came largely from the dictionary. For appropriate methods, the staff tried to think of things people/groups are doing voluntarily. The staff is hopeful the Board will come up with other ideas. It didn't want to suggest a 5 x 4 sign (such as that required for lawn applications); if a landowner wants to use a piece of poster board and a marker that might be okay. There is no minimum or maximum size to the signs in the draft policy, but that could be added by the Board.

- Granger asked whether the definition of trails as drafted would require notification for pesticide use on trails used by recreational vehicles, such as ATVs. Jennings said he thought it would as drafted.
- Flewelling asked whether the landowner had to do the posting. Jennings noted that only commercial applications under category 6B were required to post, therefore it has to do with the intent of the application. The requirement to post falls on the applicator, but they can delegate.
- Granger questioned whether this would provide a disincentive to landowners to allow ATVs to use their property. He noted that there are a lot of trails used by permission of landowners for hiking, skiing, snowshoeing, etc. Granger likes the word "marked" because then it is clear that the trail is used by the public; a lot of trails aren't used much. It would be a lot to ask to post if the trail is not generally used for hiking or biking. There would be less exposure on an ATV or snowmobile trail.
- Jennings noted that in Ogunquit there is a lot of interest in the Marginal Way Trail, and though there is no requirement to post, they have used a variety of approaches to provide notice, including use of the town website.
- Eckert said she is thinking of the Mountain Trail in Portland. It is clearly a walking trail, some of it paved, some gravel; that is the type of trail that if the railroad decides to spray, they should put up a sign. The Board should think about all the other kinds of trails, such as rights-of-way for power companies, used for walking, biking, snowmobiling, etc; The Board wouldn't expect those to be posted.
- Jennings suggested adding some adjectives, such as "clearly" or "prominently" to "marked." Side trails probably aren't likely to be treated.
- Morrill noted that it is clear what the Board wants to include, but not so clear what it doesn't want to include. A lot of landowners allow access. The Board needs to be very conscious that what it does doesn't detract from use of the land.
- Morrill remarked that the 24 hour requirement was an issue for him. In every other category there is no time frame for posting of applications other than just prior to treatment. It costs money, having to go out multiple times.
- Jemison noted that it would be nice if it were on the website 24 hours ahead so people can plan. He wouldn't want to require, but it would be nice. Eckert agreed that we should encourage the bigger trails to think ahead; if they have a website, it would be best to post ahead of time. It doesn't have to be a specific time. Morrill said it should be left up to those in charge of the application. Often weather is critical; the Board wouldn't want to delay applications because of a 24 hour requirement.
- The policy was amended consistent with the discussion
 - **Stevenson/Jemison: Moved and seconded to adopt the policy as amended**
 - **In Favor: Unanimous**

4. Consideration of a Board Policy Covering Acceptable Methods for Commercial Applicators to Positively Identify the Proper Treatment Site

At the October 24, 2014, meeting, the Board adopted an amendment to Chapter 20 which codifies a longstanding policy and will require commercial applicators to positively identify the proper treatment site using methods approved by Board policy. The existing policy needs to be slightly updated to reflect the fact that the basic requirement is now contained in rule.

Presentation By: Henry Jennings
Director

Action Needed: Review/Approve Draft Policy

- Jennings explained that because the Board had amended the rule to include the requirement “as in Board Policy,” they now needed to adopt a policy. The draft policy is virtually identical to the policy that had been in effect except that the preamble was amended. It allows flexibility and refers to rule.
- Jemison asked about properties that abut each other—where you can’t tell where one starts and the next begins. That circumstance isn’t clearly defined in this policy when the property boundaries aren’t obvious. What do we do when you’re not sure where the property line is? Morrill said that the drift rule would cover that. This policy is to ensure applicators are at the right property. Jemison said that it is appropriate to bring it up here. How do we make sure applicators are paying close attention if it’s unclear in the policy. Flewelling asked who the burden falls on; Morrill said it falls on the applicator.
- Morrill said that the Board rules are very specific with this type of issue. If you aren’t spraying the right property, that’s a violation. It happens very infrequently and is an egregious violation. It’s usually not about a fuzzy property line. It is up to the applicator and if they’re not sure they should back off and make sure.
- Jennings noted that there have been a few property line infringement cases, particularly with biting fly treatments. Customers sometimes are more concerned about making sure mosquitoes are not a nuisance than they are about property rights. As a result, companies are probably specifying that they can only treat the customer’s property.
- Morrill said that for companies doing a large volume of properties, lines are well defined prior to treating. Jemison noted that when the first contract comes up, that would be the time to verify the boundaries. Since he has been on the Board, there have been many cases. Fish said the only way is to work with the neighbor and find agreement. Applicators learn by experience; if the homeowner is telling you where the lines are, they may not be correct.
- Eckert noted that all the mechanisms described instruct the applicator to assess the site in advance of the application. Hopefully they talk to the customer and determine property lines.
 - **Eckert/Jemison: Moved and second to adopt policy as drafted**
 - **In Favor: Unanimous**

5. Consideration of a Request for Granting Continuing Education Credits for an Online Training Program

The Board received a request to grant continuing education credits for an online training course detailing the uses of Turfcide Fungicide. Historically, the staff has only approved continuing education credits for presentations made by pesticide manufacturers and distributors if they include a comprehensive review of the precautionary components of the label, such as PPE, re-entry requirements, and environmental hazards. The presentation in question is focused primarily

on the efficacy and uses of the product. Consequently, the staff is seeking Board input on how to best handle this and similar requests.

Presentation By: Gary Fish
Manager of Pesticide Programs

Action Needed: Provide Guidance to Staff on Whether to Grant Credits for Training

- Fish explained that the Board had received a request to approve online courses for continuing education credits. He referred to the materials in the Board packet. He routinely approves online courses and he requires an overview before approving them. This one looks too much like a sales pitch; there is a lot of good information, but much of it is instruction on how to use this particular product. Fish is uncomfortable approving requests like this one. On the label there is a requirement for respirators in certain situations; there are hazards to fish and aquatic organisms. There is nothing in the training about re-entry precautions. If they were to include information about these specifics, would the Board want to approve it, even though it's all about one chemical?
- Jemison said that it didn't seem too bad, if those things were added. Also, pollinator protection. Passing grade should be 80; a 70 is pitiful. Only someone who's going to use this product would go online to watch this.
- Stevenson said that the Board should trust Fish to make the call. Some courses have been really good, some have not. He agrees with John that if you're using that product, these types of courses are helpful.
- Flewelling asked whether it is common for companies to develop their own online courses; Fish said no. Flewelling suggested the Board should encourage that but give them guidelines. Why would we want to discourage that? Fish noted that he has guidelines; he is on the assessment group for the EPA and they have developed guidelines on what an online course should include. He agrees that it's good to have quality information about products as long as it's not just a sales pitch. For live training, the staff has started having trouble with some dealers giving talks which were just sales pitches. He requires them to include WPS information, all the PPE requirements, environmental hazards, and anything special on the label that applicators wouldn't necessarily be looking for.
- Eckert agreed that there has to be information about risks. Maybe also something about alternatives; chemical companies probably won't want to include that, but the Board needs to ensure that less biased information is available to applicators about downsides and alternatives. Chemical company employees should make it clear they are representing the company.
- Granger noted that if they do add the requested information and we can approve these types of courses then there are more options available to satisfy continuing education requirements. Companies can include a sales pitch if they want, but it's a bit of a stretch to allow a pure sales pitch for certification. He suggested the Board leave it up to Fish, if it's mostly sales pitch, don't approve it.
- Morrill said some of the best presentations he's gone to have been by the manufacturers. These presentations often include information on mode of action, etc. There is a pitch but they do cover the important things that Fish mentioned, like PPE. If they include that, a lot of the information is valuable, in this case information on snow mold, etc. It's a great idea to encourage free training.
- Stevenson noted that he has used products that require taking training prior to purchasing and often found them useful.
- Tim Hobbs noted that in the potato industry, when a new product is introduced, a salesman makes sure applicators know the label. If a company is willing to put in the effort, it would be a lot better than what's available now.

- Katy Green asked whether there was a concern about whether this could be viewed as an endorsement of a specific product by the Board. If there is a list on the website for specific products, what message does that send? It's obvious in the presentations there's more to it, but a list on the Board website might be misconstrued.
- Morrill suggested adding something on the website noting that credits are approved, but the products are not endorsed.

6. Consideration of a Consent Agreement with Servicios Sanchez, Inc., of East Boston, Massachusetts

On June 3, 1998, the Board amended its Enforcement Protocol to authorize staff to work with the Attorney General and negotiate consent agreements in advance on matters not involving substantial threats to the environment or public health. This procedure was designed for cases where there is no dispute of material facts or law, and the violator admits to the violation and acknowledges a willingness to pay a fine to resolve the matter. This case involved application of pesticides inconsistent with the label by a person without a valid certification or applicator's license.

Presentation By: Raymond Connors
Manager of Compliance

Action Needed: Approve/Disapprove the Consent Agreement Negotiated by Staff

- Connors explained that this case involved an application to a two-unit apartment building; the upper unit was occupied, the lower was not. The occupant called with concerns following the application. She had been given instructions to put clothes and linens in bags but leave them untied and that she and her four children should leave. When they returned they saw puddles in the bathroom and questioned whether the applicator was licensed based on how they operated. Connors spoke to Sanchez, the applicator, who said he used Hot Shot. Later a lawyer associated with the landlord sent the MSDS for Cyonara 9.7 insecticide to Randlett. The inspector collected samples; lab results came back positive for malathion in all samples, including inside the bags of clothes. No malathion products are registered for interior use. Cyonara 9.7 insecticide specifically says avoid contact with clothing. Initially, the applicator signed the consent agreement but didn't send the payment. Apparently he thought payment wasn't required until after the Board approved the consent agreement. Connors asked that Servicios Sanchez, Inc. put something in writing to show that they are no longer involved in that kind of treatment.

○ **Flewelling/Morrill: Moved and seconded to accept consent agreement as written**

- Tim Hobbs asked whether \$3,000 would cover the cost of sampling. He felt the Board should recoup the costs associated with staff time, samples, etc. for an out-of-state company. In-state companies are one thing, but the state should be recouping costs from an out-of-state company. Connors said that \$3,000 would cover the sampling, but it's difficult to factor in time.
- Randlett noted that a number of factors go into consent agreements; the time and expense involved to the Board is not one of the factors involved. There are limitations in statute on the amount of fines. Other factors include the seriousness of offense, history of company, how similar cases were treated. The staff tries to be fair and consistent. The enforcement process is not set up in a way to allow Board to recover all costs involved. In this case four violations were alleged, \$3,000 is half the maximum allowed. It is a settlement; we want to encourage them to settle.

- Jennings pointed out that fines collected go into the general fund; the Legislature doesn't want there to be incentives to the Board to levy a lot of fines. It is a losing proposition to do enforcement.
- Eckert asked whether the applicator was licensed. Randlett pointed out that an allegation about an unlicensed applicator is in paragraph 23 on the agreement.
- Blumenthal asked whether Massachusetts or other New England states had been notified. Connors replied that Massachusetts had a parallel case with the company; they took samples, and had similar findings. They had an enforcement action and the Criminal Investigation Division of EPA has been involved in looking at the company.
- Tim Hobbs noted that this is a really serious action; using malathion in a residential unit. They could kill someone; it's almost criminal.
- Eckert asked if there is any way to get the word out. Connors replied that consent agreements are on the website; it's also covered in training. Fish said that there have been presentations to landlords in the past.
- Jemison asked what the best way to control bedbugs is now. Stevenson said it is expanding: cryogenics, heat, steam, chemicals, dogs, etc. Lots of folks working on finding better products. There is no cheap way to control them; the industry is trying to develop traps.

○ **In favor: Unanimous**

7. Consideration of a Consent Agreement with Mosquito Squad of Southern Maine of Rye, New Hampshire

On June 3, 1998, the Board amended its Enforcement Protocol to authorize staff to work with the Attorney General and negotiate consent agreements in advance on matters not involving substantial threats to the environment or public health. This procedure was designed for cases where there is no dispute of material facts or law, and the violator admits to the violation and acknowledges a willingness to pay a fine to resolve the matter. This case involved commercial application to property without consent of the owner.

Presentation By: Raymond Connors
Manager of Compliance

Action Needed: Approve/Disapprove the Consent Agreement Negotiated by Staff

- Connors explained that his was an application made by a licensed applicator to a customer in Falmouth. The abutting owner observed the applicator go beyond the property line onto a section of her property. The inspector took a sample which came back positive.
- Eckert asked whether the property line was obvious. Connors replied that part of it was a chain link fence. In the disputed area there were pins with caps. Eckert asked whether the homeowner complained to the applicator; Connors replied that he didn't know.

○ **Eckert/Granger: Moved and seconded to accept consent agreement as written**

○ **In Favor: Unanimous**

8. Consideration of a Consent Agreement with Petro's Ace Hardware of Auburn, Maine

On June 3, 1998, the Board amended its Enforcement Protocol to authorize staff to work with the Attorney General and negotiate consent agreements in advance on matters not involving substantial threats to the environment or public health. This procedure was designed for cases where there is no dispute of material facts or law, and the violator admits to the violation and

acknowledges a willingness to pay a fine to resolve the matter. This case involved the distribution of general-use pesticides without a General Use Pesticide Dealer License.

Presentation By: Raymond Connors
Manager of Compliance

Action Needed: Approve/Disapprove the Consent Agreement Negotiated by Staff

- Connors explained that this involved a routine marketplace inspection which documented that the store was selling pesticides requiring a general-use pesticide dealer license. The store didn't have a license nor had they had one for several years. There was a previous consent agreement for the same violation. The staff encountered some resistance on the part of the owner to settle. In other cases we have used a \$100 base fee plus \$20 for each year not licensed (the cost of the license).
- Morrill noted that this is pretty disappointing; the company paid \$160 in 2010. A principal tenet is that there should be no economic incentive for being in violation. Morrill strongly recommend that the staff visit the store in 2015 and ensure it has a license. He encourages that the fine to be much higher next time.
- Jennings pointed out that sometimes people pay the fine and think they're licensed for a while. Morrill said he disagrees; if he gets a ticket for an unregistered vehicle he doesn't assume the fine covers the registration going forward.
 - **Flewelling/Morrill: Moved and seconded to accept consent agreement as written**
 - **In Favor: Unanimous**

9. Presentation on State Specific Managed Pollinator Protection Plans

The federal Environmental Protection Agency (EPA), in collaboration with other federal agencies, is developing a series of measures designed to improve protection of pollinators from pesticide-related risks. One of the proposed measures involves development of state-specific plans for protecting managed pollinators. The advantage of state plans is that it allows states to tailor protections to match specific local needs and conditions, while avoiding the potential pitfalls of a one-size-fits-all standard. The staff will provide an overview of the state-specific protection plans.

Presentation By: Gary Fish
Manager of Pesticide Programs

Action Needed: None—Informational Only

- Jennings explained that EPA is looking to states to create state-specific plans; he is not sure if they will be mandatory. State plans allow states to tailor concerns and policies to issues prominent in that state and dependant on what crops and systems are in place in that state. Listening to Tony Jadczyk (State Apiarist) at the pollinator conference, it is clear that there are areas where we should get agricultural producers and apiarists together. It's certain that a lot of bees are brought in from out of state for blueberries. EPA is hoping that states will have something in place by 2015. The Board needs to decide whether to ignore the idea or pursue it. We should identify areas where we can communicate better and work together. Jennings has heard some sentiment that some managed bee contractors won't come back to the state unless something is done. Does the Board want to start or wait and see what EPA does?
- Flewelling noted that the legislature clearly wants something done. Should start the ball rolling.

- Jennings said there are 80,000 hives brought in each year for blueberries. The higher the density of plants, the more pollinators needed to maximize blueberry yields. Apples also use managed pollinators, but Jennings hasn't heard the same kinds of concerns in the apple industry.
- Granger asked whether EPA would be doing any outreach on this. Jennings said it is not yet clear whether it is mandatory or optional. There have been a series of webinars and listening sessions put on by EPA. There has been some discussion about some labels being contingent upon existence of a state plan. It wouldn't likely happen in a short time frame. The blueberry industry would benefit from some sort of discussion on how to improve communication.
- Granger said it's easy to think about killing bees directly, but it's also about habitat; not killing bees directly but killing the weeds that pollinators rely on. It may affect farmer's ability to manage weeds. The devil is in the details; it may not be in the purview of the Board to look at all these things, but would be in the purview of the Department of Agriculture. Maybe it should be the Department, not the Board, working on this.
- Tim Hobbs remarked that he went to the pollinator conference and there was a lot of interest in the topic; over 250 people there, including people from Massachusetts and other states. Their concern is with bee management; there may be a role with neonics, but even eliminating them will not solve the problem. It's a popular idea that neonics are killing bees; nothing will change some people's minds. He is concerned about label restrictions based on a state plan with little guidance from EPA. When you look at neonics as a percentage of the whole issue, it's not very big. Let's not feed the frenzy because there's no science to back it up. Let's be cautious in embracing a cause because it may be used to build momentum in the legislature. He is fearful that the Board might vilify a pesticide and/or a pesticide use and it's not going to solve the problem. There was a big die-off of bees that went from blueberries to cranberries; neonics were definitely not the cause. Communication is good, but let's be cautious.
- Jemison said there were some really important points brought up at the conference, for instance: not all neonics are equal in toxicity; interactive effects that we can't ever have enough money to look at, but we need to be aware of them.
- Jemison asked whether the Department tracks where managed bees go in the state. If he was contracted to bring in a bunch of bees, could his neighbor go on a website and see they're there so he knows he shouldn't spray fungicide?
- Jennings said that in talking to Tony over the years, especially around blueberries, there's been about 10 bee kills in the last 30 years, almost always because one company doesn't know what the next company is doing. That's why communication is the key.
- Eckert asked, what is a pollinator plan? It's not only a pesticide issue; there are agricultural commodities that rely on contracted pollinator services.
- Morrill said there will be a lot of inputs. Is the Board the right venue to start the process where we may only be a small piece of the puzzle? The Department of Agricultural may want to be the lead. He suggests waiting to see what the guidance is from EPA which should be available by the January Board meeting. It may point more to Department than to the Board. He suggested putting it on the agenda for the next meeting after we see what the EPA guidance is.
- Jennings asked Tim Hobbs whether his concern was that if the Board takes the lead it will look like we're saying it's a pesticide issue. Hobbs said yes; Jennings noted that seemed to be Granger's concern as well. Morrill agreed: pesticides are part of the puzzle, but not the whole puzzle.

10. Interpretation of CMR 01-026, Chapter 10, Section 2 (P) (2), Definition of Property Open to Use by the Public

State statutes define pesticide applications made to property open to use by the public as commercial applications requiring a licensed applicator. Section 2 (P) (2) of Chapter 10 defines

property open to use by public while exempting property “where the public has not been permitted upon the property at any time within seven days of when the property received a pesticide application.” This exemption has been used for different outdoor purposes, but the most common use is by land trusts to treat for invasive plants when they post the treated area and indicate the area (but not the entire “property”) is temporarily closed to the public. The staff has received a question from a hotel owner who interprets that exemption as applying to hotel rooms provided that the room is not occupied for seven days following the pesticide application. Because indoor pesticide applications present unique risks to persons using the indoor space, the staff would like guidance on how to interpret the Chapter 10 definition.

Presentation By: Gary Fish
Manager of Pesticide Programs

Action Needed: Provide Guidance on Interpretation of the Chapter 10 Definition

- Fish explained that this exemption is mostly used by land trusts for invasive weed control. They post the area that’s treated and make it off limits for seven days, and the Board has been okay with that. The question is how to define the word “property”. Should they have to close the entire property or is it okay to just close the area that’s treated? How does that translate to indoor situations, like in a hotel? If they want to make an area off limits for seven days, should it be just the room or the apartment or the entire building?
- Morrill noted that in the Sanchez case (above) there was still residue a month after treatment.
- Eckert asked how long residues exist indoors. Is one room closed off safe? Will exposure move between rooms?
- Randlett said that the rule includes the words “occupied apartments” so by this definition unoccupied apartments would not require the use of a licensed applicator. The Board could extend that definition to hotel rooms as well or it could say that they are not the same because of size, adjacency, etc. The Board could make the argument that there’s a higher risk when treating hotel rooms.
- Fish asked how it fits with section 2(P)1B where application of pesticides for any form of remuneration is defined as a custom application and remuneration includes “rent”. Randlett said that under Section 2(P)2B it’s silent as to whether unoccupied apartments are open to use by the public. It would be a stretch because the rule has identified “occupied apartments” as areas open to the public.
- Stevenson noted that with indoor applications, the risks are different; ventilation issues; dust; seven days later there’s no change in risk.
- Eckert noted that we probably want to encourage people to treat when rooms are unoccupied. How long should it be before occupancy is allowed?
- Jennings said the third question is: what is the Board’s position concerning a proper standard of care around indoor applications? Maybe the Board needs to work on these definitions; the risks are so much higher indoors. Sanchez shows you the potential for harm.
- Morrill said the entire property should have to be closed. If people are in the other apartments, they are still in the building.
 - **Consensus reached that hotels and apartment buildings should use a licensed applicator unless the entire property is unoccupied.**
- Randlett noted that this will cause some conflict because the rule specifies “occupied apartments” and is silent about “unoccupied apartments.” The Board could adopt an interim policy, but it may not be enforceable. Rulemaking should be done.
- Jennings said that the value of an interim policy is that it informs the regulated community of the Board’s intentions. The rule is currently ambiguous, people have interpreted it differently.

He agreed it may cause difficulties in enforcement issues and the Board should ultimately do rulemaking to clean up the language.

- Regarding outdoor applications, Eckert said that if they post and make the area inaccessible for a week, that protects visitors but doesn't protect the people doing the applications.
- Morrill said that it also doesn't protect the water. Are unlicensed people aware of the rules? Fish noted that the staff has done training with land trusts.
- Katy Green asked if the cost of the license is what's preventing them from getting licensed. Jennings said that it's really the time that it takes; each land trust must have a master applicator, which is a minimum of four tests.
- Morrill noted that a lot of companies like doing pro bono work for land trusts.

- **Consensus reached to table until the next meeting when Bohlen is in attendance.**

11. Formation of an Advisory Committee to Develop Guidelines Related to the Issuance of Variance Permits for Spraying Railroads Adjacent to Surface Waters

At the May 16, 2014, meeting, the Board granted a one-year variance from Section 6 of Chapter 29 to Asplundh Tree Expert Company—Railroad Division to make broadcast herbicide applications less than 25 feet from surface water. At that time, the Board also directed the staff to develop guidelines/criteria for issuance of railroad variances prior to next season. The staff will present some ideas about forming a small committee to develop draft guidelines for Board consideration.

Presentation By: Henry Jennings
Director

Action Needed: Provide Guidance to Staff

- Jennings explained that at the May meeting there was discussion of a variance to Asplundh to treat railroads and there was some angst about the products they were using because of mobility and persistence; it's similar to the issue with compost. The Board granted a one year variance and agreed to get a committee together to look at the issue over the winter. Jennings talked to Bob Moosmann at MDOT; the state owns half the rail in the state now. MDOT is very cautious. However, in some circumstances, contractors are essentially spraying herbicides on rock right up to the edge of the water. This is a long term concern going back at least 15 years. Railroads didn't like it when we said they shouldn't apply diuron right up to the water's edge; they still spray 15 feet away. A committee might include Chateauvert from Railroad Weed Control, Inc., who has been willing to work with MDOT. They might be willing to share their standard of care. Moosmann recommended MDOT rail manager, Jeff Pitcher. Jemison mentioned including a weed scientist; maybe also include a water quality specialist.
- Morrill asked, what is the goal for the committee? Jennings replied that the Board felt it lacked objective criteria for approving/disapproving variances. In the past the Board has said that it wants variances to be consistent with MDOT model, but we're not sure what that model entails. Moosmann is a big proponent of adding a sticker to the spray mix. Railroad tracks are often right along the edge of the water in some locations. The end goal is to give the Board a better sense of expectations when approving variances.
- Morrill said the variance to Asplundh was for using a product that others said they wouldn't use. The committee should talk about products specifically. Advisory committee should include MDOT and railroad folks so they have their science straight.
- Eckert suggested writing BMPs. Jennings agreed; Moosmann has always advocated for not doing applications in May because the water table is higher; other companies don't want to agree to that; it's more than just products.

- Jemison and Morrill noted that the committee should be small; five at most.
- Jennings asked whether a weed scientist should be included. Granger said that it needs to be more than just applicators making the protocol. Morrill noted that while MDOT is a great resource they may be relying on old information. Jemison said that he would suggest someone; maybe someone from out of state who could skype in to meetings.
- Morrill noted that this all started with a specific variance that included a specific product. Be cognizant of people's time; look at products, application time frames, adjuvants, nozzle sizes and rates.
 - **Consensus that Jennings could choose weed specialist, that Jemison would serve as water quality specialist, and that Jennings should bring guidelines to the Board once they are complete.**

12. Other Old or New Business

- a. Other?

13. Schedule of Future Meetings

January 14 (Maine Agricultural Trades Show), March 13, April 24, and June 5, 2015 are tentative Board meeting dates. The Board will decide whether to change and/or add dates.

Action Needed: Adjustments and/or Additional Dates?

- No additional dates were added

14. Adjourn

- **Jemison/Stevenson: Moved and seconded to adjourn at 11:13**
- **In favor: Unanimous**



PAUL R. LEPAGE
GOVERNOR

STATE OF MAINE
MAINE DEPARTMENT OF AGRICULTURE, CONSERVATION AND FORESTRY
BOARD OF PESTICIDES CONTROL
28 STATE HOUSE STATION
AUGUSTA, MAINE 04333-0028

WALTER E. WHITCOMB
COMMISSIONER
HENRY S. JENNINGS
DIRECTOR

BOARD OF PESTICIDES CONTROL

January 14, 2015

Augusta Civic Center, 76 Community Drive, Kennebec/Penobscot Room, Augusta, Maine

MINUTES

3:00 – 4:00 PM BOARD MEETING

4:00 – 5:00 PM OPEN FORUM

5:00 – 6:00 PM BOARD MEETING CONTINUED IF NECESSARY

Present: Bohlen, Eckert, Flewelling, Granger, Jemison, Morrill, Stevenson

1. Introductions of Board and Staff

- The Board, Staff, and Assistant Attorney General Randlett introduced themselves.
- Staff Present: Chamberlain, Connors, Hicks, Jennings, Patterson, Tomlinson

2. Minutes of the December 5, 2014, Board Meeting

Presentation By: Henry Jennings
Director

Action Needed: Amend and/or Approve

- Minutes were not available for review.

3. Request from Maine Migrant Health Program and Eastern Maine Development Corporation to Help Support a Worker Safety Training Program for Summer 2015

Since 1995, the Board has supported a Migrant and Seasonal Farmworker Safety Education program. During 2014, 274 individuals received Worker Protection Standard (WPS) training, 218 individuals received take-home exposure training, and 278 received heat stress training. The Maine Migrant Health Program and Eastern Maine Development Corporation are proposing to provide one health-and-safety outreach worker trainer during the 2015 agricultural season. Funding to support this effort is being requested in the same amount as last year and funding has been accounted for in the Board's FY'15 budget.

Presentation By: Chris Huh, Program Manager, Farmworkers Jobs Program,
Eastern Maine Development Corporation

Elizabeth Charles, Enabling Services Coordinator, Maine Migrant Health Program

Action Needed: Discussion and Determination if the Board Wishes to Fund this Request

- Elizabeth Charles, Maine Migrant Health Program, explained that in 2014 they hired one person rather than the two they had hired in the past. They were still able to meet all requests from growers by staggering start days for different crops. The woman they hired had worked for AmeriCorps in 2007 so she was able to hit the ground running. The trainer presented standardized WPS curriculum, farmworker opportunity curricula, and pesticide safety around families and children. The training also included heat stress prevention. The trainer did some training with dairy farms, and formed new relationships there. Charles stated they want to continue the same model in 2015. They are requesting \$3,500 from BPC, which is the same as last year. A requirement of the farmworker opportunity funds is pre- and post-tests. They would be happy to provide data if it would be valuable. Fish agreed that he would look at the data.
 - **Jemison/Eckert: Moved and seconded to approve grant**
 - **In Favor: Unanimous**

4. United Phosphorus, Inc., Request to Renew Its FIFRA Section 24(c), Special Local Need Registration for Asulox[®] Herbicide (EPA# 70506-139) for Control of Bracken Fern on Low Bush Blueberries

At its November 5, 2010, meeting, the Board approved a Special Local Needs [24(c)] registration for the use of Asulox Herbicide (EPA# 70506-139) for bracken fern control in wild blueberries. This label allows for spot treatment of bracken fern only during the non-bearing year. That registration expired November 5, 2014; University of Maine Blueberry Extension Specialist Dr. David Yarborough, and the product registrant, United Phosphorus, Inc. are requesting a five-year renewal of the 24(c) registration.

Presentations By: Mary Tomlinson
Pesticides Registrar and Water Quality Specialist

Action Needed: Approve/Disapprove 24(c) Registration Request

- Tomlinson explained that this request from Dr. David Yarborough is the same as the previous registration, which expired after five years. He is requesting another five-year registration. The label is the same; the need still exists; nothing has changed.
- Jemison asked if the reason we haven't tested for this in water is because we didn't have the capacity. Tomlinson replied that it is not in the screen that was used. Jemison asked when the sampling down gradient from blueberry fields was conducted; Tomlinson said that in 2014 there were just three sample points. Jemison asked why we don't ask if they used this product; Tomlinson said the staff talks to the homeowner, not the grower.
- Jemison said that he doesn't have a big problem with it but the application rate is one gallon per acre/3.3 pounds active ingredient per gallon; it sticks around for a while; that's a lot of material. Hicks noted that it is for spot treatments. Jemison said that a spot could be quite large, especially for bracken fern. In the 25 foot zone around water, the Board determined spot treatment was not more than 100 sq. ft. or 20% of the area within 25 feet of the water/wetland. This product is not used a lot, they just want to have in their toolbox, but Jemison would still like to see us test for it. Tomlinson said she has inquired of the lab if they can test for it, still waiting for an answer. It would be a separate analysis. Jemison noted that it's hard to justify if you can't ask whether the product was used.
- Bohlen said it is important to think about what other goals the Board wants to accomplish with water sampling, given limited resources. If you don't know whether it's being used, it's not going to tell you much. Jemison agreed it would be a waste of money if testing were done where the product wasn't used, but he said he has concerns because it is a toxic product, being applied in high amounts.
- Jennings said it might be necessary to design a different study; in the last one the staff used a system of random points which didn't include many places where there were houses near blueberry fields.

- Granger noted that the registration is only for five years; it will have to be reviewed again at that time.
 - **Granger/Flewelling: Moved and seconded to approve registration**
 - **In Favor: Unanimous**

5. Consideration of a Staff Request to Refer an Enforcement Matter to the Office of the Attorney General

The Enforcement Protocol describes the Board’s recommended procedures for resolving violations of pesticide law of sufficient public consequence to warrant a formal enforcement response. In matters where the alleged violator and the Board staff cannot agree on a resolution, the protocol specifies that the case be placed on a meeting agenda for Board consideration. The staff is presenting a case in which an unlicensed company advertised for and conducted mosquito control services.

Presentation By: Raymond Connors
 Manager of Compliance

Action Needed: Determine Appropriate Enforcement Response

- Connors explained that this case started in May 2013 with a call about a brochure circulating in southwest Maine advertising pest control services by a person the caller thought was unlicensed. The inspector got a copy of the brochure; the company is called Bug Guys. The inspector went to the address where he saw a pickup truck with application equipment in it. He met with the owner/operator who said he put the brochures out as a feeler but had not done any work. There were three testimonials in the brochure; he said he treated the yards of friends. He admitted he made some applications in 2012 using Mosquito Barrier but didn’t have records. The inspector took a picture of the container of the product he said he used. Connors tried to call the company owner to discuss a settlement but couldn’t get a response. He sent a consent agreement by certified mail; it came back undeliverable. Randlett then sent a letter and received a voice mail message in response. The company owner indicated that the activity he was doing wasn’t an issue and did not respond to calls after that. He had taken the core and category exams in the past but did not pass and did not reschedule. He was obviously aware of the process. The staff has been unable to reach a settlement and would like the Board to refer the case to the Attorney General for resolution as the Board’s Enforcement Protocol stipulates.
- Morrill noted that the person in question was sent a letter in December and invited to attend; he asked if he was in attendance. No one responded.
- Granger asked if he is still practicing. Connors replied that the message on his phone is Painters Plus and Bug Guys, so he seems to still be soliciting for commercial work.
- Flewelling asked if anyone had an application done by this person. Connors said the staff could not locate any customers, because he wouldn’t really admit that he has any. The inspector indicated he had verbally acknowledged that he had applied Mosquito Barrier to customer’s properties. Standard practice is to meet with a customer; he wouldn’t give us information on who the customers were, but he provided details on how the application was made. Evidence indicates that he has done commercial work, is soliciting commercial work, and is aware of the licensing requirements.
- Eckert asked what the Mosquito Barrier contains. Connors said it contains 25b ingredients; the brochure talks about products plural, so the staff isn’t sure if Mosquito Barrier is the only product used.
 - **Flewelling/Eckert: Moved and seconded to refer to the Attorney General**
 - **In Favor: Unanimous**

6. Consideration of a Consent Agreement with Charles A. Dean Hospital of Greenville

On June 3, 1998, the Board amended its Enforcement Protocol to authorize staff to work with the Attorney General and negotiate consent agreements in advance on matters not involving substantial threats to the environment or public health. This procedure was designed for cases where there is no dispute of material facts or law, and the violator admits to the violation and acknowledges a willingness to pay a fine to resolve the matter. This case involved the unlicensed application of an ant control product on multiple occasions by the maintenance staff at a hospital.

Presentation By: Raymond Connors
Manager of Compliance

Action Needed: Approve/Disapprove the Consent Agreement Negotiated by Staff

- Connors explained that the staff conducted a routine pesticide use inspection at a critical access hospital in Greenville. In the course of talking to the maintenance supervisor, the inspector noticed that there was a buffing and burnishing product container with the words “kills ants and ant spray” handwritten on it. The supervisor denied any knowledge but another employee said it contained Orange Guard; the supervisor admitted buying it at a local hardware store and using it to control ants in patient rooms the previous summer. The hospital acknowledged the violations, signed and paid the consent agreement.
- Jemison asked what Orange Guard is and whether it is a 25b; Connors said it is a citrus extract; Tomlinson said that it is not a 25b product, it has an EPA registration number.
 - **Jemison/Stevenson: Moved and seconded to approve consent agreement as written**
 - **In Favor: Unanimous**
- Eckert noted that this is not the first hospital to come before the Board. Are they not aware? Should we send them a notice? Morrill remarked that it might be difficult to get a letter to the proper person. Will it reach the person responsible for cleaning? Connors believed it would be better to send it to administrators. Eckert agreed that the administrators are the ones that need to get the message to the employees that it’s not okay to go out and buy products even if they seem safe.
 - **Consensus reached to send a letter to hospitals about pesticide use and licensing.**

7. Consideration of a Consent Agreement with Dan Davis of Corinna

On June 3, 1998, the Board amended its Enforcement Protocol to authorize staff to work with the Attorney General and negotiate consent agreements in advance on matters not involving substantial threats to the environment or public health. This procedure was designed for cases where there is no dispute of material facts or law, and the violator admits to the violation and acknowledges a willingness to pay a fine to resolve the matter. This case involved the purchase of a restricted-use pesticide by an unlicensed applicator.

Presentation By: Raymond Connors
Manager of Compliance

Action Needed: Approve/Disapprove the Consent Agreement Negotiated by Staff

- Connors explained that this case stemmed from the same inspection of the pesticide dealer in the Dan Brown case. This individual purchased a restricted use pesticide; he acknowledged that he did not have a license at the time of purchase, signed the consent agreement and paid the fine.

- Flewelling asked if Northeast Ag was fined also. Connors explained that when the consent agreement around the pesticide storage facility in Aroostook County was negotiated, this was rolled into it, as well as the sale to Dan Brown.
- Jennings noted that the staff had, per the Board's instruction, included information to restricted use dealers in the renewal letter this year, and sent via email earlier.

- **Bohlen/Eckert: Moved and seconded to approve consent agreement as written**

- Stevenson commented that the average customer has an expectation when they make a purchase that it is a legal purchase. Is this someone who would know? Connors said that the purchaser's son is licensed as a commercial applicator, which is not valid for this type of purchase. Jennings said the federal government draws a very distinct line between private and commercial use: a commercial applicator may not apply restricted use pesticides to their own property for agricultural purposes.

- **In Favor: Unanimous**

8. Update on Water Quality Monitoring Activities

7 M.R.S. § 607-A, Section 2-A, directs the Board to conduct water residue surveys, for both ground and surface water, in order to prepare profiles of the kinds and amounts of pesticides present. Over the last 12 months, the Board's staff has been involved in both ground water sampling and marine sediment sampling. The staff will update the Board on those activities and the sampling results.

Presentations By: Mary Tomlinson
Pesticides Registrar and Water Quality Specialist

Action Needed: None – Informational Only

- Tomlinson explained that groundwater sampling was conducted in March and April. Samples were sent to the Montana lab which tested for 96 pesticides. Thirty-two wells were positive; 23 analytes detected for a total of 81 hits. Ten wells were very low in terms of concentrations. Details are in the memo. One well was re-tested because the numbers were above the Maximum Contaminant Level; Jemison has agreed to work with us to try to mitigate impacts on that well.
- The staff also sampled 20 marine sediment sites from Kittery to Cobscook Bay in conjunction with the lobster Environmental Risk Advisory Committee (ERAC), including urban, suburban and rural sites. Southwest Research Institute did not have very low detection limits; the results were not that useful. The Montana lab did have detections for several sites. The staff was surprised by the detection of cypermethrin. It will be interesting to retest that site and see what is found.
- Bohlen pointed out that this was designed as a screening test, so sites were deliberately picked to represent the sites most likely to have detectable residues. The staff deliberately looked where there was an expectation of finding something; it wasn't random; it's important to keep that in mind.
- Hicks said there needs to be a discussion on the detection limits and what they mean. USDA labs look for residues on food and have very low detection limits. All the food levels are higher than what we found in the samples sent to the Montana lab. Also of interest is the variation between detection limits. The detection limit for bifenthrin is lower than most of the other analytes, which could be a partial explanation for the prevalence of the bifenthrin positives as opposed to the other pyrethroids.
- Jemison asked if there is a sense of what the results really mean. Hicks and Tomlinson agreed that more work needs to be done to determine that. Bohlen said they need to look at the toxicity numbers and relate those numbers to the detection limits of things that weren't detected. Hicks said they also need to look at whether residues are bioavailable and how tightly are they bound to the sediment. She also noted that the Montana water screen can't be done using salt water, only fresh water. Bohlen noted that the focus was on areas where we thought there was a high potential for runoff.

The sample size was too small, but as a first conclusion, we are seeing the pyrethroids getting into the marine environment where we thought we would find them. This was designed as the pilot year, not as a big statistical study, and it worked for that.

9. Update on Managed Pollinator Protection Plans

At the December 5, 2014, meeting, the staff provided the Board with an overview of Managed Pollinator Protection Plans which are being promoted by the federal Environmental Protection Agency (EPA) as part of its overall strategy for reducing pesticide risks to pollinators. EPA guidelines had not yet been published, but states were being encouraged to start working on state-specific plans. After some discussion the Board reached consensus that because pollinator protection consists of more than pesticides alone, the Department, or the Bureau of Agriculture, Food and Rural Resources should take the lead role on a state plan. The Board requested an update once the EPA guidance is publicly available.

Presentation By: Henry Jennings
Director

Action Needed: None – Informational Only

- Jennings said he had participated in a conference call with EPA; they are pushing state lead agencies to start working on state-specific plans. In the Board packet is a draft Pollinator Protection Plan guidance policy from EPA. At the last meeting, the Board indicated that the issue was broader than pesticides and the BPC should not be in charge of the plan. Jennings spoke to Ellis Additon, the Bureau Director, and while the department clearly has a vested interest, there is a lot going on. Jennings isn't sure where it will fall in the list of priorities. There are five bills in the legislature around pesticides, two of them are acts to protect pollinators. It's more difficult to be compelling in testimony if we're not doing anything. At this point, instructions to the staff were to pass the message on to the department and the staff has done that. Board members can read the guidance from EPA themselves. A lot of it is around communication. Some have observed that the EPA guidance really focuses on managed bees and does nothing for other pollinators, but there is nothing to prevent the state from looking at the broader issue.
- Eckert noted that a lot of the guidance seems to focus on mapping and asked if anything is being done in Maine. Are there any ideas on how to do the mapping that would be acceptable to the bee-keeping community?
- Bohlen said he was struck with the commonalities with other issues, mostly around communication. There is an urban component, sensitive areas for aerial spraying, identifying key locations and, figuring out who to talk to. It looks like the same problems. Barriers to implementing an online tool to assist with communication are that it's big and it's expensive. We need to get on this, the same issue around geography keeps coming up.
- Connors noted that apiaries are defined as sensitive areas and they are registered with the Department.
- Morrill said that the Department needs to be taking the lead on this. At the pollinator conference, Frank Drummond said 90% was other issues, 10% are pesticide problems. There should be a lot of others working on getting this done.
- Jennings noted that a couple of years ago we looked into a mapping program run by Purdue called DriftWatch. The interesting part is that it deals with two types of sensitive areas, beekeepers and organic farmers. At the time it was \$25,000 to sign up; that may have changed. A number of other states have signed on. Beekeepers mark their location, the applicator marks a location, then an auto email notice is sent. The staff could take a fresh look at that. Bohlen said that might be cheaper than trying to build something.

- Jemison said that if we can figure out a notification process for this, the Board would have a roadmap for any type of notification. If the Board doesn't do it, or lead it, it's not clear when or if it will happen. Seems like it's a pretty big priority.
- Tim Hobbs asked how EPA defines a managed pollinator; is it one hive or some other number? Is it many hives specifically for pollination, or can anyone sign on? Jemison said that if someone has hives, they have a purpose, and would like to succeed. If you're actively working at it, you wouldn't want someone to do something that defeats your purpose. Hobbs said that this came as an edict from the White House; the people writing the rules have never seen the equipment, so we have no idea what their definition is or what the intent is. It's a much bigger issue if it's all pollinators, not just managed hives. Fish said the intention was for "registered" beekeepers; he doesn't know what the qualifications are. Bohlen said he felt they referred it to the states to define that.
- Jemison said that at the meeting in Machias the Board heard from at least two beekeepers who were concerned about the health of bees and wanted to be notified when pesticides were going to be applied.
- Granger said he is concerned that we already have two types of regulatory systems for notification. Nothing is settled. There will always be bills coming in around notification, but he is uncomfortable with a notification system that's inconsistent with the rest of agriculture. Morrill said we should look at the rules we already have; the guidelines from EPA might be followed with our current rules. Granger said he would like to see it worked around the rules already in place. Fish noted that the issue with bees is that they can travel two to three miles, so 500 feet might not be enough.
- Stevenson asked what a beekeeper does if he's notified. Fish replied that he cover the hives temporarily. Bohlen noted that if there are a lot of applications, the hives might be covered a lot. Fish said it would depend on what was used, whether it's going to be on something the bees would forage on. Applicators shouldn't really be applying to sites the bees would forage on anyway. It could be an orchard with clover underneath, or a lawn with dandelions. Those are the kinds of things that cause conflict. Granger suggested the best outcome might be BMPs.

10. Other Old or New Business

a. Other

- Jennings noted that the ERAC minutes were available. Bohlen suggested calling them DRAFT until they had been formally approved by the committee.
- Jennings noted that the list of bills had been posted and that there are five bills around pesticides and one funding bill, as well as the two around the Board's major substantive rulemaking. He said he would email the bills to the Board members as soon as they are printed. He noted again that it is difficult for the Board to take a position on a bill they haven't seen. They probably wouldn't meet between the time they are printed and the public hearing. The Department may take a position on some. Jennings asked Randlett what he could do as far as representing the Board's position on the bill; Randlett said the Board can only take a position on a bill by voting on it during a public meeting.

11. Schedule of Future Meetings

March 13, April 24, and June 5, 2015, are tentative Board meeting dates. The Board will decide whether to change and/or add dates.

- Adjustments and/or Additional Dates?
 - Some discussion ensued about possible places to meet this summer. Consensus was reached to have a meeting in eastern Maine and include a public listening session, a field trip to a blueberry operation and the Cooperative Extension Experimental Station. Staff will explore options.

12. Adjourn

- **Jemison/Flewelling: Moved and seconded to adjourn at 4:58 PM**
- **In Favor: Unanimous**



PAUL R. LEPAGE
GOVERNOR

STATE OF MAINE
DEPARTMENT OF AGRICULTURE, CONSERVATION AND FORESTRY
BOARD OF PESTICIDES CONTROL
28 STATE HOUSE STATION
AUGUSTA, MAINE 04333-0028

To: Board of Pesticides Control Members
From: Mary Tomlinson, Pesticides Registrar/Water Quality Specialist
RE: FIFRA Section 18 recertification request for use of HopGuard II to control Varroa mites in honey bee colonies
Date: March 13, 2015

This request to seek recertification of Maine's 2014 FIFRA Section 18, 14-ME-01, for the use of HopGuard (potassium salt of hop beta acids), to control Varroa mites in honey bee colonies, is submitted at the request of Tony Jadcak, State Apiarist. Varroa mites continue to be a major pest of honey bees in Maine.

Approval of this request will ensure beekeepers will continue to have another control option available in lieu of other products to which mites are resistant, as well as provide an organic alternative for use during honey production. HopGuard II, extracted from hops (*Humulus lupulus*), has demonstrated miticidal activity. In vivo studies have shown that HopGuard II strips are effective in killing Varroa mites without harming bees.

According to the registrant, the EPA has pushed back the approval date for the Section 3 label to October, 2015.

The attached recertification package includes the following documents for your review. Please let me know if you have any questions.

1. 2014 Final Report and 2015 Amendments – Section 18 HopGuard II
2. Letter of support from Tony Jadcak, Maine State Apiarist
3. Letter of support from John Forte, BetaTec Hop Products, Inc.
4. Draft Maine Section 18 HopGuard II label with use directions
5. HopGuard II container label
6. HopGuard II application pictogram

**FIFRA SECTION 18 EMERGENCY SPECIFIC EXEMPTION
FOR THE USE OF HOPGUARD II TO CONTROL VARROA MITES IN
HONEY BEE COLONIES IN MAINE**

2014 Final Report

File Symbol: 14-ME-01

Tony Jadczyk, Maine State Apiarist
Mary Tomlinson, Maine Pesticides Registrar

Maine Board of Pesticides Control
Maine Department of Agriculture, Conservation and Forestry
State House Station 28
Augusta, Maine 04333-0028

March 13, 2015

**Section 18 Emergency Exemption 2014 Final Report
for Use of HopGuard II (potassium salt of hop beta acids) to Control
Varroa Mite, *Varroa destructor*, in Honeybee Colonies in the State of Maine**

This is a Section 18 Specific Exemption final report in compliance with § 166.32, Reporting and recordkeeping requirements for specific, quarantine, and public health exemptions.

The Varroa mite is a widespread pest in honeybee colonies, affecting adult bees and reducing honey production in Maine. HopGuard II, containing potassium salt of hop beta acids, is an effective alternative among available control options, being an effective miticide while not affecting colony behavior.

(1) Total colonies treated and total quantity used under the exemption:

During the period of April, 2014 to December 31, 2014, approximately 2070 honey bee colonies were treated with HopGuard II (Beta acids) throughout Maine. This estimate is based upon the sale of 127 kits (42 50-strip kits and 85 24-strip kits), for a total of 4,140 strips, sold in the state during the period and an application rate of two HopGuard II strips/hive. The total amount of active ingredient used was 12,192 grams (2100 strips at 1.92 g A.I./strip + 2040 strips at 4 g A.I./strip).

(2) Discussion of effectiveness of the pesticide in dealing with the emergency condition:

The efficacy of HopGuard II for Varroa control was consistent with USDA and BetaTec reports.

(3) A description of any unexpected adverse effects which resulted from use of the pesticide under the exemption:

There were no reports of adverse effects related to treatment of hives with HopGuard II in 2014. Beekeepers were advised to refrain from treating hives in cold weather when bees are in tight cluster based on 2012 experience.

4) The results of any monitoring required and/or carried out under the exemption:

Random inspections immediately following HopGuard II treatment verified good Varroa control. Subsequent treatments were warranted for hives actively rearing brood.

(5) A discussion of any enforcement actions taken in connection with the exemption:

No enforcement action was carried out under this exemption.

(6) Method(s) of disposition of a food crop, if required to be destroyed under an exemption:

No disposition was required.

(7) Any other information requested by the Administrator:

No other information was requested by the Administrator.

**Amendments to 2014 FIFRA Section 18 Emergency Specific Exemption
for the 2015 Use of HopGuard II to Control Varroa Mites In Honey Bee Colonies in Maine**

The following revisions have been made to Section 18 Emergency Specific Exemption, 14-ME-01, for use of HopGuard II, in 2015.

40 CFR 166.20(a)(3): Description of Proposed Use

(v) Total number of honey bee colonies to be treated:

The number of potential colonies to be treated is estimated at 10,000 based upon previous use.

(vi) Total amount of pesticide proposed (active ingredient and product):

A maximum of 240 kg (529.11 lbs.) A.I.; a maximum of 60,000 strips is expected to be used.

Assuming that 100% of the 10,000 honey bee colonies in Maine will be treated with six strips (two strips per brood chamber) up to three times per year (usually spring, summer and fall); a maximum of 60,000 strips may be used. If 100% of the honey bee colonies in Maine are treated, then the total amount of hop beta acids applied in Maine will be 240 kg (60,000 strips x 4 grams of potassium salt of hop beta acids per strip), which is equivalent to 529.11 lbs.



STATE OF MAINE
DEPARTMENT OF AGRICULTURE, CONSERVATION AND FORESTRY
DIVISION OF ANIMAL AND PLANT HEALTH
28 STATE HOUSE STATION
AUGUSTA, MAINE 04333-0028

WALTER E. WHITCOMB
COMMISSIONER

E. ANN GIBBS
ACTING DIRECTOR

PAUL R. LEPAGE
GOVERNOR

February 11, 2015

Mary E. Tomlinson
Pesticide Registrar/Water Quality Specialist
Maine Board of Pesticide Control
28 State House Station
Augusta, ME 04333

Dear Ms. Tomlinson,

On behalf of Maine's beekeeping industry and the agricultural commodities that rely upon honey bees and beekeepers for crop pollination purposes, I support the Section 18 Emergency Exemption for HopGuard II (beta acids) that was granted by the US-EPA April 23, 2014 and expired December 31, 2014.

Hopguard is an effective Varroa mite treatment that provides control consistent with studies conducted by the USDA and the registrant, BetaTec Hop Products (a division of John I. Hass, Inc.). The product provides beekeepers with an alternative Varroa control that is both valuable for mite resistance management and an organic Varroa mite treatment alternative.

A repeat of this Section 18 Emergency Exemption is necessary so beekeepers have an alternative Varroa treatment option in lieu of materials that now have wide-spread resistance (Apistan, CheckMite) in addition to an organic Varroa mite control that can be used while bees are producing surplus honey.

A healthy beekeeping industry is essential for agricultural production in Maine and the U.S. for honey production and pollination purposes. Thank you for considering this matter.

Sincerely,

A handwritten signature in cursive script that reads "Anthony Jadczyk".

Anthony Jadczyk
State Apiarist



5185 MacArthur Boulevard, NW
Suite 300
Washington, DC 20016-3341
Tel: (202) 777-4800
Fax: (202) 777-4895

November 13, 2014

Mary E. Tomlinson
Pesticide Registrar/Water Quality Specialist
Maine Board of Pesticides Control
28 State House Station
Augusta, ME 04333

Dear Ms. Tomlinson

BetaTec Hop Products (a division of John I. Haas, Inc.) is actively working with USDA-ARS to bring to market HopGuard®II (a Beta Acids rich fraction) for the control of the Varroa mite in the beehive. We fully support the Maine Department of Agriculture's request for a Section 18 emergency exemption for the use of our product.

BetaTec Hop Products, Inc. has committed to provide sufficient product, properly labeled, for this emergency use when it is granted by the EPA. We have submitted a Section 3 application to the EPA and would expect approval in 2015.

We thank both the Beekeepers Associations and the State of Maine for their support in this endeavor. If you have any questions of me, please do not hesitate to let me know.

Best regards,

A handwritten signature in black ink, appearing to read "John N. Forte". The signature is fluid and cursive, with a long, sweeping underline that extends to the left.

John N. Forte
Vice President
BetaTec Hop Products, Inc.

EMERGENCY EXEMPTION USE DIRECTIONS

EPA FILE SYMBOL XX-ME-XX

STATE: Maine

CHEMICAL: Potassium Salt of Hop Beta Acids (HopGuard®II)

CROP / SITE: Honey Bees / All counties in the state of Maine

PEST: *Varroa destructor*

EFFECTIVE: Month Day, 2015 to December 31, 2015

PRECAUTIONARY STATEMENTS

Product may cause eye irritation – flood eyes with plenty of water if contact is made with eyes. Wearing protective eyewear when handling treated strips will reduce the potential for eye irritation. Avoid contact with skin, eyes or clothing. Wash thoroughly with soap and water after handling and before eating, drinking, chewing gum or smoking tobacco. Remove and wash contaminated clothing before reuse.

PERSONAL PROTECTIVE EQUIPMENT

Applicators must wear chemical-resistant gloves when handling treated strips.

DIRECTIONS FOR USE

Package - Strips must be applied at the rate of three half strips per 2 lb. or 3 lb. package of adult worker bees. Cut strips in half and attach three half strips to the top of package so that the strips are hanging within the package. Place bees in the package after the strips are attached. The bees should remain in contact with the strips for at least 48 hours.

Colony - Strips must be applied at the rate of one strip per five deep combs covered with bees in each brood super or for example two strips per ten frame brood super (chamber) when all the combs are covered with bees. Strips are to be placed only in the brood chamber (not in the honey super). Folded strips must be opened and hung over one of the center brood frame with one-half of the strip on each side of the frame. If using a second strip, apply it to an adjacent center frame about four inches away from the first strip. Strips must be placed hanging between frames, and within the colony cluster, and not laid on top of the frames. Leave the strips in the colony for 30 days. Retreat, as necessary, up to three times per year.

A maximum of three applications per year (six strips or approximately 24.0 grams of potassium salt of hop beta acids) per ten frame brood super (chamber) is allowed. This limit includes all applications to the package (if applicable) and to the colony. Application timing (usually during spring, summer or fall) should be based on the levels of Varroa mites observed in the colony. Users may not take honey and wax from the brood chambers, only from the honey supers. For optimal results, apply HopGuard®II when little to no brood is present in the colony.

The use directions must be in the possession of the user at the time of application.

Any adverse effects resulting from the use of HopGuard®II under this emergency exemption must be immediately reported to the Maine Department of Agriculture (toll free 1-800-242-7535).

Storage and Disposal

Unused strips should be stored in a tightly sealed, cool, dark area. Unused, unregistered product must either be returned to the manufacturer or distributor in unopened containers or disposed of in accordance with the Resource Conservation Recovery Act following the expiration of this emergency exemption.

RESISTANCE MANAGEMENT

Using this product in rotation with another approved miticide with a different mode of action will decrease the potential for Varroa mites to develop resistance. If the strip remains in the hive more than 30 days, remove.

Manufactured by: BetaTec Hop Products, Inc., A Division of John I. Haas, Inc., 1600 River Road, Yakima, WA 98902

efficient by nature™

HOPGUARD® II

(Formulated as impregnated cardboard strips.)

SECTION 18 SPECIFIC EXEMPTION

THIS IS AN UNREGISTERED PRODUCT AND MAY BE USED FOR DISTRIBUTION AND USE ONLY IN STATES WITH A VALID SECTION 18 EXEMPTION AUTHORIZATION. THE EXEMPTION IS EFFECTIVE FROM **XXX**, 2015 AND EXPIRES ON DECEMBER 31, 2015.

For use in honey bee colonies to control Varroa mites (*Varroa destructor*)

ACTIVE INGREDIENTS:	BY WEIGHT
Potassium Salt of Hop Beta Acids.....	16.0%
INERT INGREDIENTS:	84.0%
TOTAL	100.0%

KEEP OUT OF REACH OF CHILDREN PRECAUTIONARY STATEMENTS

Product may cause eye irritation – flood eyes with plenty of water if contact is made with eyes. Wearing protective eyewear when handling treated strips will reduce the potential for eye irritation. Avoid contact with skin, eyes or clothing. Wash thoroughly with soap and water after handling and before eating, drinking, chewing gum or smoking tobacco. Remove and wash contaminated clothing before reuse.

PERSONAL PROTECTIVE EQUIPMENT

Applicators must wear chemical-resistant gloves when handling treated strips.

DIRECTIONS FOR USE

Bee Package- Strips must be applied at the rate of three half strips per 2 lb. to 3 lb. package of adult worker bees. Cut strips in half at the fold and attach three half strips to the top of package so that the strips are hanging within the package. Place bees in the package after the strips are attached. The bees should remain in contact with the strips for at least 48 hours.

Colony - Strips must be applied at the rate of one strip per five frames covered with bees in each brood chamber or two strips per ten frames covered with bees in the brood chamber. Strips are to be placed only in the brood chamber (not in the honey super). Folded strips must be opened and hung over one of the center brood frames with one-half of the strip on each side of the frame as shown in the pictogram. If using a second strip, apply it to an adjacent center frame about four inches away from the first strip. Strips must be placed hanging between frames, and within the colony cluster, and not laid on top of the frames. Leave the strip(s) in the colony for 30 days. Honey bees tend to chew the cardboard strips; however, remove any remaining strips after 30 days. Retreat, as necessary, up to 3 times per year.

Application Rate- Strips are saturated with liquid and should be applied “as is”. Do not remove the liquid from the strip. A maximum of 3 applications per year (6 strips) or approximately 24.0 grams of potassium salt of hop beta acids per ten frames of bees in the brood chamber is allowed. This limit includes all applications to the bee package (if applicable) and to the colony. Application timing should be based on the levels of Varroa mites observed in the colony. Users may not take honey and wax from the brood chambers, only from the honey supers. HopGuard is not temperature sensitive and can be applied in the brood chamber during honeyflow. Honey supers can remain in the colony during treatment. For optimal results, apply HopGuard®II when little to no brood is present in the hive.

Any adverse effects resulting from the use of HopGuard®II under this emergency exemption must be immediately reported to your State Department of Agriculture.

RESISTANCE MANAGEMENT

Varroa mite populations can become resistant to pesticides. Resistance development is affected by both the frequency of application and rate/dose of application. After an application, the more susceptible pests die and the less susceptible ones survive, mate with other survivors, and reproduce. Most of the ensuing offspring inherit the parental resistance. Additional applications continue to kill only the remaining susceptible individuals. Continued reliance on a single class of miticide or miticide with the same mode of action will select for resistant individuals which will dominate the mite population in subsequent generations. In order to prevent resistance development and to maintain the usefulness of individual pesticides the adoption of an appropriate resistance management strategy is vital. The Mode of Action (MOA) for hop beta acids is undefined at this time; however, it may cause death by asphyxiation by penetration of the pest’s thin exoskeleton.

To delay resistance:

- When possible, rotate the use of miticides to reduce selection pressure as compared to repeatedly using the same product, mode or action or chemical class. If multiple applications are required, use a different mode of action each time before returning to a previously-used one.
- Base miticide use on Integrated Pest Management (IPM). This includes proper pest identification, monitoring for locality specific economic threshold and economic injury levels, record keeping, and utilizing all available control practices (cultural, biological and chemical).
- Maximize efficacy by following all label instructions including dosage and timing of application.
- Continually monitor treated populations for development of miticide resistance and report suspected resistance to local extension specialists.

- Contact your local extension specialist for additional pesticide resistance/management recommendations and/or IPM recommendations for your specific location.
- For further information or to report suspected resistance contact your local extension specialist.
- Remove strips if still in hive after 30 days.

RESTRICTIONS

- For in-hive use only.
- Maximum rate = 2 strips per brood chamber per application (i.e., one strip per five frames covered with bees).
- Remove remaining strip(s) after 30 days.
- Do not use HopGuard®II more than 3 times per year.

STORAGE AND DISPOSAL

Unused strips should be stored in a tightly sealed, cool, dark area. Unused, unregistered product must either be returned to the manufacturer or distributor in unopened containers or disposed of in accordance with the Resource Conservation Recovery Act following the expiration of this emergency exemption.

NET CONTENTS

Each HopGuard®II kit contains 24 cardboard strips. Each strip is folded in half and contains 4.0 grams of potassium salt of hop beta acids, and the kit contains 96.0 grams (3.4 ounces) of potassium salt of hop beta acids.

Manufactured by: BetaTec Hop Products, Inc., A Division of John I. Haas, Inc., 1600 River Road, Yakima, WA 98902

efficient by nature™

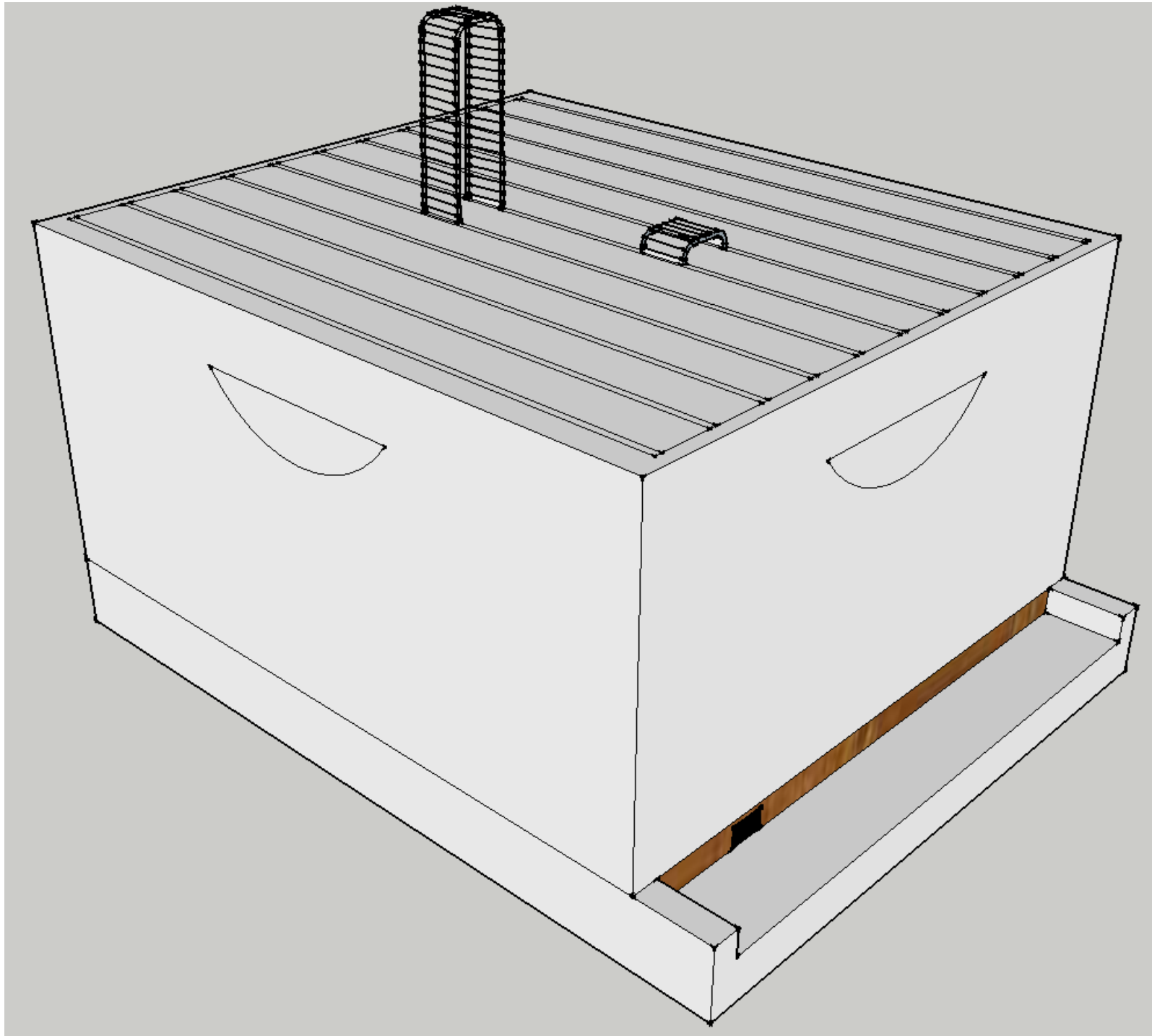

01 DEPARTMENT OF AGRICULTURE, CONSERVATION AND FORESTRY

026 BOARD OF PESTICIDES CONTROL

Chapter 22: STANDARDS FOR OUTDOOR APPLICATION OF PESTICIDES BY POWERED EQUIPMENT IN ORDER TO MINIMIZE OFF-TARGET DEPOSITION

SUMMARY: These regulations establish procedures and standards for the outdoor application of pesticides by powered equipment in order to minimize spray drift and other unconsented exposure to pesticides. The primary purpose of these regulations is to implement the legislative mandate of the Board, as expressed by 7 M.R.S.A. §606(2)(G), to design rules which “minimize pesticide drift to the maximum extent practicable under currently available technology.”

SECTION 1. EXEMPTIONS

The regulations established by this chapter shall not apply to pesticide applications in any of the following categories:

- A. Applications of pesticides confined entirely to the interior of a building;
- B. Applications of pesticides by non-powered equipment;
- C. Applications of pesticides exclusively in granular or pelletized form;
- D. Applications of pesticides injected underground or otherwise injected directly into the target medium. Such applications must involve no spraying of pesticides whatsoever.

SECTION 2. STANDARDS OF CONDUCT FOR PESTICIDE APPLICATIONS

All pesticide applications subject to these regulations shall be undertaken in compliance with the following standards of conduct:

- A. **Equipment**
 - I. Pesticide spray equipment shall be used in accordance with its manufacturer’s recommendations and instructions, and shall be in sound mechanical condition, free of leaks and other defects or malfunctions which might cause pesticides to be deposited off-target.
 - II. Pesticide spray equipment shall be properly calibrated consistent with Board or University published guidance. Sufficient records to demonstrate proper calibration must be maintained and made available to representatives of the Board upon request.

- III. Pesticide application equipment shall have properly functioning shut-off valves or other mechanisms which enable the operator to prevent direct discharge and minimize drift to non-target areas. Spray equipment designed to draw water must also have a properly functioning antisiphoning device.

B. Weather Conditions

- I. Spray applications shall not be undertaken when weather conditions favor pesticide drift onto Sensitive Areas or otherwise prevent proper deposition of pesticides on target.
- II. Pesticide application must cease immediately when visual observation reveals or should reveal that spray is not being deposited on target.
- III. Without limitation of the other requirements herein, under no circumstances shall pesticide application occur when wind speed in the area is in excess of 15 miles per hour.

C. Identifying and Recording Sensitive Areas

- I. Prior to spraying a pesticide, the applicator must become familiar with the area to be sprayed and must identify and record the existence, type and location of any Sensitive Area located within 500 feet of the target area. Applicators shall prepare a site map or other record, depicting the target area and adjacent Sensitive Areas. The map or other record shall be updated annually. The site map or other record shall be retained by the applicator for a period of two years following the date of applications and shall be made available to representatives of the Board upon request.
- II. This requirement shall not apply to commercial applications conducted under categories 3A (outdoor ornamental tree and plant), 3B (turf), 6A (rights-of-way vegetation management), 6B (industrial/commercial/municipal vegetation management), ~~or 7A (structural general pest control applications)~~, or 7E (biting fly & other arthropod vectors [ticks]).

D. Presence of Humans, Animals

Pesticide applications shall be undertaken in a manner which minimizes exposure to humans, livestock and domestic animals.

The applicator shall cease spray activities at once upon finding evidence showing the likely presence of unprotected persons in the target area or in such proximity as to result in unconsented exposure to pesticides.

E. Other Requirements

These regulations are intended to be minimum standards. Other factors may require the applicator to take special precautions, beyond those set forth in these regulations, in

order to avoid adverse impacts on off-target areas and to protect public health and the environment.

SECTION 3. STANDARDS FOR AERIAL APPLICATION OF PESTICIDES

A. Positive Identification of the Target Site

The person contracting for an aerial pesticide application shall ensure that the application site (i.e., target area) is positively identified prior to application, using a unique and verifiable method, including:

- I. An onboard, geo-referenced electronic mapping and navigation system (e.g., GPS); or
- II. Effective site markings visible to the applicator; or
- III. Other method(s) approved by the Board.

B. Site Plans Required

Prior to spraying by aerial application within 1,000 feet of a Sensitive Area Likely to Be Occupied, the person contracting for the application shall provide to the applicator a site plan that includes:

- I. a site map drawn to scale that:
 - (i) delineates the boundaries of the target area and the property lines;
 - (ii) depicts significant landmarks and flight hazards;
 - (iii) depicts the type and location of any Sensitive Area Likely to Be Occupied within 1,000 feet of the target area; and
 - (iv) depicts other Sensitive Areas within 500 feet of the target area.
- II. If applicable, a school bus schedule shall accompany the site map.
- III. The site plan and site map with identified sensitive areas required under Section 3(B) shall be retained by the applicator for a period of two years following the date of applications and shall be made available to representatives of the Board upon request.
- IV. Compliance with this section satisfies the requirements of Section 2(C).

C. Site-Specific Application Checklist

Prior to conducting an aerial pesticide application within 1,000 feet of a Sensitive Area Likely to Be Occupied, the applicator shall complete a Board-approved pre-application

checklist for each distinct field or target site. The checklist shall be maintained by the applicator for a period of two years and shall be available for inspection by representatives of the Board at reasonable times, upon request. The checklist shall include, at a minimum, the following elements:

- I. The date, time, description of the target site and name of the applicator;
- II. Confirmation that the notification requirements contained in CMR 01-026, Chapters 28 and 51, have been carried out;
- III. Confirmation that the target site has been positively identified;
- IV. The location of where weather conditions are measured and a description of the equipment used to measure the wind speed and direction;
- V. Confirmation that conditions are acceptable to treat the proposed target site, considering the location of any Sensitive Area Likely to Be Occupied and current weather conditions;
- VI. Wind speed and direction;
- VII. The measures used to protect all Sensitive Areas;
- VIII. Confirmation that there are no humans visible in or near the target area.

D. Buffer Zones for any Sensitive Area Likely to Be Occupied

Aerial applicators shall employ site-specific buffer zones adjacent to any Sensitive Area Likely to Be Occupied sufficient to prevent unlawful pesticide drift, unless consent has been granted by the landowner, lessee and occupant (when applicable), consistent with the provisions of Section 4(C) of this rule.

E. Wind Speeds for Aerial Applications

Unless otherwise specified by the product label, an applicator may not conduct an aerial application of pesticides within 1,000 feet of a Sensitive Area Likely to Be Occupied unless the wind speed is between 2 and 10 miles per hour.

SECTION 4. GENERAL STANDARDS FOR OFF-TARGET PESTICIDE DISCHARGE AND RESIDUE

A. Prohibition of Unconsented, Off-Target Direct Discharge of Pesticides

Pesticide applications shall be undertaken in a manner which does not result in off-target direct discharge of pesticides, unless prior authorization and consent is obtained from the owner or lessee of the land onto which such discharge may occur in a manner consistent with the pesticide label.

B. Standards for Unconsented, Off-Target Drift of Pesticides

- I. **General Standard.** Pesticide applications shall be undertaken in a manner which minimizes pesticide drift to the maximum extent practicable, having due regard for prevailing weather conditions, toxicity and propensity to drift of the pesticide, presence of Sensitive Areas in the vicinity, type of application equipment and other pertinent factors.
- II. **Prima Facie Evidence.** Pesticide residues in or on any off-target Sensitive Area Likely to Be Occupied resulting from off-target drift of pesticides from a nearby application that are 1% or greater of the residue in the target area are considered prima facie evidence that the application was not conducted in a manner to minimize drift to the maximum extent practicable. The Board shall review the site-specific application checklist completed by the applicator and other relevant information to determine if a violation has occurred. For purposes of this standard, the residue in the target area, and the residue in the Sensitive Area Likely to Be Occupied, may be adequately determined by evaluation of one or more soil, foliage or other samples, or by extrapolation or other appropriate techniques.
- III. **Standard of Harm.** An applicator may not apply a pesticide in a manner that results in:
 - (i) Off-target pesticide residue detected in or on any nearby crop which violates EPA tolerances for that crop, as established under 40 CFR, Part 180.
 - (ii) Off-target pesticide residue detected in or on any nearby organic farm or garden which causes the agricultural products thereof to be excluded from organic sale in accordance with 7 CFR, Part 205, Section 205.671.
 - (iii) Off-target pesticide residue detected on any nearby persons or vehicles using public roads.
 - (iv) Documented human illness. For this standard to be met, the Board must receive verification from two physicians that an individual has experienced a negative health effect from exposure to an applied pesticide and that the effect is consistent with epidemiological documentation of human sensitivity to the applied pesticide.
 - (v) Off-target damage or injury to any organism.
- IV. **Enforcement Considerations.** The Board shall consider the particular circumstances of violations arising from Subsections 4(B)(I) and (III) in determining an appropriate response, including, but not limited to:
 - (i) The standard of care exercised by the applicator;
 - (ii) The degree of harm or potential harm that resulted from or could have resulted from off-target drift from the application;

- (iii) The risk (toxicity and exposure) of adverse effects from the pesticide applied.

C. **Consent**

- I. **Consent, How Given.** Authorization and consent by the owner or lessee and occupant (when applicable) of land receiving a pesticide discharge or drift in a manner consistent with the pesticide label may be given in any manner, provided that the consent is reasonably informed and is given prior to the onset of the spray activity in question. The burden of proof shall be upon the applicator to demonstrate that requisite authorization and consent has been given. For this reason, applicators are encouraged to obtain such consent in writing and to maintain records thereof.
- II. The residue and harm standards in Sections 4(B)(II) and (III) for off-target drift do not apply where the owner, lessee and occupant (when applicable) of the off-target area receiving the pesticide drift have given authorization and consent as prescribed in Section 4(C).
- III. Except with the prior written approval of the Board, no authorization or consent may be given with regard to off-target direct discharge or off-target drift of pesticides upon any bodies of water or critical areas as defined in CMR 01-026, Chapter 10, "Definitions; Sensitive Area."

SECTION 5. **VARIANCES FROM STANDARDS**

A. **Variance Permit Application**

An applicator may vary from any of the standards imposed under this chapter by obtaining a permit to do so from the Board. Permit applications shall be made on such forms as the Board provides and shall include at least the following information:

- I. The name, address, and telephone number of the applicant;
- II. The area(s) where pesticides will be applied;
- III. The type(s) of pesticides to be applied;
- IV. The purpose for which the pesticide application(s) will be made;
- V. The approximate date(s) of anticipated spray activities;
- VI. The type(s) of spray equipment to be employed;
- VII. The particular standards from which the applicant seeks a variance;

- VIII. The particular reasons why the applicant seeks a variance from such standards, including a detailed description of the techniques to be employed to assure a reasonably equivalent degree of protection and of the monitoring efforts to be made to assure such protection;
- IX. The names and addresses of all owners or lessees of land within 500 feet of the proposed spray activity, and evidence that such persons have been notified of the application. The Board may waive this requirement where compliance would be unduly burdensome and the applicant attempts to notify affected persons in the community by another means which the Board finds reasonable.

B. Board Review; Legal Effect of Permit, Delegation of Authority to Staff

- I. Within 60 days after a complete application is submitted, the Board shall issue a permit if it finds that the applicant will achieve a substantially equivalent degree of protection as adherence to the requirements of this chapter would provide and will conduct spray activities in a manner which protects human health and the environment. Such permit shall authorize a variance only from those particular standards for which variance is expressly requested in the application and is expressly granted in the permit. The Board may place conditions on any such permit, and the applicant shall comply with such conditions. Except as conditioned in the permit, the applicant shall undertake spray activities in accordance with all of the procedures described in the application and all other applicable legal standards. Permits issued by the Board under this section shall not be transferable or assignable except with further written approval of the Board and shall be valid only for the period specified in the permit.
- II. The Board may delegate authority to review applications and issue permits to the staff as it feels appropriate. All conditions and limitations as described in Section 5(B) I shall remain in effect for permits issued by the staff. If the staff does not grant the variance permit, the applicator may petition the Board for exemption following the requirements set forth in 22 MRSA §1471-T, "Exemptions."

SECTION 6. EMERGENCIES

- A. In the event that severe pest or weather conditions threaten to cause a significant natural resource and/or economic loss, as determined by the Commissioner of the Maine Department of Agriculture, Conservation and Forestry, the requirements contained in Section 3 of this Chapter shall be waived, subject to the following conditions:
 - I. The severe pest and/or weather conditions must necessitate immediate wide-scale aerial application of pesticides.
 - II. The immediate need for aerial pesticide application does not provide sufficient time to complete the requirements of Section 3 of this Chapter,
 - III. Prior to any aerial application, the Commissioner shall issue a press release notifying residents of affected regions about the emergency, the likelihood of

aerial application in the affected regions and the approximate dates that the emergency may continue.

- IV. The Commissioner, in consultation with the Board's staff, shall specify the requirements in Section 3 that will be waived.
 - V. Land managers and aerial applicators shall make good faith efforts to comply with the intent of Section 3 and minimize off-target drift to Sensitive Areas.
- B. When the Maine Center for Disease Control and Prevention (CDC) recommends control of disease vectors, government sponsored vector control programs are exempt from Sections 2C, 2D, 3B, 3C, 3D, 3E and 4 of this chapter, provided that reasonable efforts are made to avoid spraying non-target areas.

June 12, 2009 amendments become effective on January 1, 2010

STATUTORY AUTHORITY: 7 M.R.S.A. §606(2)(G):
22 M.R.S.A. §1471-M(2)(D)

EFFECTIVE DATE:
January 1, 1988

AMENDED:
October 2, 1996

EFFECTIVE DATE (ELECTRONIC CONVERSION):
March 1, 1997

AMENDED:
September 22, 1998 - also converted to MS Word
January 4, 2005 – filing 2004-603 affecting Section 3.B.II.(iii)
January 1, 2010 by request of agency in filing 2009-252
June 12, 2013 – filing 2013-135 (Emergency major substantive)

CORRECTIONS:
February, 2014 - formatting

**BASIS STATEMENT FOR ADOPTION OF
CMR 01-026, CHAPTER 22—STANDARDS FOR OUTDOOR APPLICATION OF
PESTICIDES BY POWERED EQUIPMENT IN ORDER TO MINIMIZE OFF-TARGET
DEPOSITION**

Basis Statement

The requirement to identify and map sensitive areas (which include areas likely to be occupied) serves little purpose in a residential area. Consequently the Board exempted common residential ornamental, turf, and outdoor structural general pest control applications when the rule was originally promulgated in 1987. Instead, the Board required applicators to post treated areas under Chapter 28. In recent years, the Board observed that there are now a couple of other types of common residential pesticide applications: biting fly and tick applications and certain types of application made under the industrial/commercial/municipal vegetation management category. Consequently, the Board proposed exempting these applications from the requirement to identify sensitive areas under Chapter 22 in exchange for a posting or notification requirement in Chapter 28. Applicators treating vegetation on trails and sidewalks would need to also implement a drift management plan

In addition, the Board saw little value in identifying sensitive areas for common right-of way (category 6A) spraying and proposed exempting this category from the requirement to identify sensitive areas in exchange for implementing a drift management plan and publishing notice of the application in the newspaper under Chapter 28.

Comments received during the comment period were mostly positive, however some questioned the need for a “drift management plan” since the entirety of Chapter 22 is intended to control drift. The Board agreed with these comments and determined the public interest is best served by adopting the amendments as proposed except for the requirement to implement drift management plans for vegetation control programs (category 6A and sidewalks and trails in category 6B).

Impact on Small Business

In accordance with 5 MRSA §8052, sub-§5-A, a statement of the impact on small business has been prepared. Information is available upon request from the Maine Board of Pesticides Control office, State House Station #28, Augusta, Maine 04333-0028, telephone 207-287-2731.

Provisional Adoption

At its October 24, 2014 meeting, the Board provisionally adopted the major substantive amendments to Chapter 22.

Legislative Approval

On February 24, 2015 the Joint Standing Committee on Agriculture, Conservation and Forestry (ACF) held a public hearing on LD 202, the resolve authorizing final adoption of the amendments. Subsequently the ACF reported the resolve out as ought-to-pass. The Legislature enacted the resolve and it became law as emergency legislation without the Governor’s signature on March 29, 2015 (Resolve 2015, Chapter 5).

Rulemaking Statement of Impact on Small Business

5 MRSA §8052, sub-§5-A

Agency

Department of Agriculture, Conservation and Forestry—Maine Board of Pesticides Control

Chapter Number and Title of Rule

CMR 01-026, Chapter 22—Standards for Outdoor Application of Pesticides by Powered Equipment in Order to Minimize Off-Target Deposition

Identification of the Types and an Estimate of the Number of the Small Businesses Subject to the Proposed Rule

There may be as many as 200 small businesses making residential and right-of-way pesticide applications that will be affected by the proposed amendments to Chapter 22.

Projected Reporting, Record Keeping, and Other Administrative Costs Required for Compliance with the Proposed Rule, including the Type of Professional Skills Necessary for Preparation of the Report or Record

The proposed amendments will significantly reduce the administrative costs for businesses that treat for ticks and biting flies and/or do certain types of vegetation management applications.

Brief Statement of the Probable Impact on Affected Small Businesses

Record keeping for small businesses that make treatments as described above should be significantly reduced.

Description of Any Less Intrusive or Less Costly, Reasonable Alternative Methods of Achieving the Purposes of the Proposed Rule

Since there are no anticipated increased burdens on small businesses, there are no less intrusive or less costly alternatives.

SUMMARY: These regulations establish procedures and standards for informing interested members of the public about outdoor pesticide applications in their vicinity. This chapter sets forth the requirements for requesting notification about pesticide applications, for posting property on which certain commercial pesticide applications have occurred and also establishes the *Maine Pesticide Notification Registry* structure and fees.

Section 1. Requesting Notification About Outdoor Pesticide Applications

The purpose of the following notification requirement is to enable individuals an opportunity to obtain information regarding outdoor pesticide application activities in their vicinity.

A. Requests for Notification; How Made

The owner, lessee or other legal occupant of a sensitive area may make a request to be notified about any outdoor pesticide application(s) which may occur within 500 feet of that sensitive area and any aerial application(s) which may occur within 1,000 feet of the sensitive area.

1. The request may be made in any fashion, so long as it is effective in informing the person receiving the request of the name, address, telephone number, and interest in receiving notification of the person making the request.
2. The request for notification should be made to the person responsible for management of the land on which the pesticide application will take place. If the person making the request for notification is uncertain as to the identity of the person to whom the request should be made, he/she may make the request for notification to the person who owns the land involved, as such ownership is ascertainable from the tax records of the municipality. That landowner shall then be responsible for assuring compliance with provisions of this section.

B. Procedure of Notification

Once a request for notification has been made as provided in Section 1(A), the person receiving the request shall cause notification to be given as follows:

1. General notification of intent to apply pesticides out-of-doors shall be given to the person making the request for notification. Such general notification may be given in any fashion, provided that it is effective in informing the person receiving the notice of the following:

- a. the approximate date(s) when pesticide(s) may be applied;
- b. the pesticide(s) which may be applied;
- c. in general terms, the manner of application; and
- d. the name, address and telephone number of a person responsible for the pesticide application from whom additional information may be obtained.
- e. If requested, the person responsible for managing the land shall make reasonable efforts to supply a copy of the MSDS(s) and/or the pesticide label(s). However such requests for additional information will not delay nor prohibit the intended pesticide application.

Where feasible, such general notification shall be given within one week after the request for notification is received and at least one day before any pesticide application is to occur. Such notification may cover outdoor pesticide applications which are planned over a period of up to one growing season.

2. If, following receipt of the general notification as provided by Section 1(B)(1) above, the person seeking notification believes there is a need for additional or updated information regarding impending pesticide application activities, he/she may make a further request for additional information from the person identified in the general notification. This request for additional information must specify the type of information needed, including, for example, more specific information regarding the date or dates on which pesticides will be applied when known. The person responsible for the notification shall make reasonable efforts to comply with such request for additional information.
3. If any person is dissatisfied with the efforts made by any other person at complying with these notification provisions, a complaint may be filed with the Board. The Board shall then make efforts to attempt to reach a reasonable and fair resolution between the parties.

Section 2. *Maine Pesticide Notification Registry for Non-Agricultural Pesticide Applications*

The Board shall maintain a list of individuals who must be notified of outdoor, non-agricultural pesticide applications in their vicinity. This list shall be referred to as the *Maine Pesticide Notification Registry*.

A. *Individuals to be Included on the Registry*

1. Individuals requesting to be listed on the *Maine Pesticide Notification Registry* shall pay all appropriate fees and provide the following information on forms supplied by the Board:
 - a. Name;

- b. Mailing address;
 - c. Listed registry residence, including street or road address and city;
 - d. Daytime and evening telephone number(s), one of which is designated as the primary contact number; and
 - e. The names and addresses of all landowners or lessees within 250 feet of the boundary of the listed registry residence.
2. Individuals may register more than one residence by completing additional forms and paying all appropriate fees.
 3. The effective period of the registry will be from March 1 to February 28 of the following year. Individuals must submit their request for inclusion on the next effective registry by December 31. All submissions received after that date will be included on the following registry. Individuals may notify the Board at any time of changes in their listed registry residence, however, changes will not take effect until the following registry. An individual will not be considered officially included on the *Maine Pesticide Notification Registry* unless their name appears on the current effective registry.
 4. The Board shall mail renewal notices to individuals listed on the *Maine Pesticide Notification Registry* on or before November 1 of each year. An individual must re-apply and pay all appropriate fees annually to remain on the registry for the next twelve month period.

B. Alerting Neighbors to the Presence of an Individual on the Registry

1. All individuals on the *Maine Pesticide Notification Registry* shall annually provide a letter to all landowners and lessees within 250 feet of their property boundary from whom they want to receive notification.
2. This letter, approved and supplied by the Board, must inform neighbors of the existence of the *Maine Pesticide Notification Registry*, the individual's request to be notified in the event of an outdoor pesticide application, the distance from the property boundary which shall cause notification to be given for non-agricultural pesticide applications, and the notification requirements of this chapter.
3. The individual on the registry requesting notification bears the burden of proof for demonstrating that this provision has been met.
4. Failure to distribute the letter will not prohibit an individual from being added to or remaining on the registry.

C. Registry Provided to Commercial Applicators

The *Maine Pesticide Notification Registry* shall be printed and distributed annually to affected licensed Commercial Master Applicators on or before its effective date of March 1. Newly licensed Commercial Master Applicators will be provided a copy of the current effective registry upon licensing.

D. Notification to Individuals on the *Maine Pesticide Notification Registry*

1. Commercial applicators shall notify an individual listed on the registry when performing an outdoor, non-agricultural pesticide application that is within 250 feet of the property boundary of the listed registry residence.
2. A person who receives a letter in accordance with Section 2(B) and who performs any outdoor, non-agricultural pesticide application within 250 feet to the property boundary of the listed registry residence shall notify the individual from whom the letter was given or sent.
3. Notification must consist of providing the following information to the individual on the registry:
 - a. The location of the outdoor pesticide application;
 - b. The date and approximate start time of the pesticide application (within a 24 hour time period) and, in the event of inclement weather, an alternative date or dates on which the application may occur;
 - c. The brand name and EPA registration number of the pesticide product(s) which will be used; and
 - d. The name and telephone number of the person or company making the pesticide application.
4. An individual on the registry who receives notification may request a copy of the pesticide product label or Material Safety Data Sheet. The person or company performing the pesticide application shall make reasonable efforts to comply with such request for additional information. However, such requests for additional information will not delay nor prohibit the person or company from performing the pesticide application as scheduled.
5. Notification must be received between 6 hours and 14 days prior to the pesticide application.
6. Notification must be made by telephone, personal contact or mail.
 - a. In cases where personal contact with the individual listed on the registry is not achieved, notification requirements are met via telephone if:

- i. the information is placed on a telephone answering device activated by calling the individual's primary contact telephone number; or
 - ii. the information is given to a member of the household or workplace contacted by dialing the primary contact telephone number.
 - b. If notification cannot be made after at least two telephone contact attempts and personal contact is not feasible, notification may be made by securely affixing the notification information in written form on the principal entry of the listed registry location.
7. The person or company performing the pesticide application bears the burden of proof for demonstrating that they have complied with this section.

E. Exceptions

1. Any person providing written notices to property owners in accordance with Chapter 51, "Notice of Aerial Pesticide Applications," shall be exempt from this section.
2. The following types of pesticide applications do not require notification under this section:
 - a. The application of pesticides indoors;
 - b. Agricultural pesticide applications;
 - c. The outdoor commercial application of pesticides to control vegetation in rights-of-way in certification and licensing category 6A (rights-of-way vegetation management) ~~categories VI(A) (utility rights of way), VI(B) (roadside vegetation management), and VI(C) (railroad vegetation management)~~;
 - d. The outdoor commercial application of pesticides in certification and licensing category ~~VII(a)~~ 7A (structural general pest control) within five (5) feet of a human dwelling, office building, institution such as a school or hospital, store, restaurant or other occupied industrial, commercial or residential structure which is the intended target site;
 - e. The application of general use pesticides by hand or with non-powered equipment to control stinging insects;
 - f. The placement of pesticidal baits;
 - g. The injection of pesticides into trees or utility poles;

- h. The placement of pesticide-impregnated devices on animals, such as ear tags and flea collars;
- i. The application of pesticidal pet supplies, such as shampoos and dusts;
- j. The application of disinfectants, germicides, bactericides and virucides, such as bleach. The use of disinfectants in the pressure-washing of the exterior of buildings is not exempt under this section;
- k. The application of insect repellents to the human body;
- l. The application of swimming pool products;
- m. The application of general use paints, stains, and wood preservatives and sealants applied with non-powered equipment or by hand or within an enclosure which effectively prevents the escape of spray droplets of the product being applied; and
- n. The injection of pesticides into wall voids.

F. Exemption from this section

If an individual on the current effective registry and a person or company performing pesticide applications subject to this rule can reach an agreement on notification provisions acceptable to both parties other than those described herein, then the requirements as described in this section may be waived. For such an exemption to be in effect, the details of the notification agreement must be placed in writing and signed by both parties. Either party may terminate the notification agreement with a 14-day, written notice.

G. Fee

The annual application fee for an individual requesting to be on the registry will be \$20.00. The Board may waive the fee for individuals who demonstrate an inability to pay, or where other extenuating circumstances exist which justify granting a waiver. Evidence of an individual's inability to pay shall include, but not be limited to, the individual's participation in any of the following programs:

- 1. Food Stamps
- 2. Temporary Assistance for Needy Families (TANF)
- 3. Supplemental Security Income (SSI)
- 4. Social Security Disability (SSD)
- 5. Maine Care (Medicaid)

Requests for a fee waiver must be in writing and be made by the individual at the time of application for listing on the registry. The written request must contain sufficient

information for the Board to determine that a basis for granting a fee waiver has been demonstrated in accordance with this rule.

Section 3. Public Notice and Posting Requirements for Certain Pesticide Applications in ~~Certain Commercial Licensing Categories~~

A. Sidewalks and Trails

Public notice must be provided consistent with Board policy for the outdoor commercial application of pesticides within category 6B to sidewalks and trails.

B. Posting

1. Categories Requiring Posting

- a. 3A (outdoor ornamentals)
- b. 3B (turf)
- c. 6B (industrial/commercial/municipal vegetation management), except applications to sidewalks, trails, railroad sidings, and power substations
- d. 7A (general pest control)
- e. 7E (biting fly & other arthropod vectors)

2. Posting Requirements

~~Where outdoor commercial pesticide applications in certification and licensing categories III(a) Outdoor Ornamentals, III(b) Turf, and VII(a) Structural General will take place, the area~~ Areas treated under the categories listed in Section 3B(1) shall be posted in a manner and at locations designed to reasonably assure that persons entering such area will see the notice. Such notice shall be posted before application activities commence and shall remain in place at least two days following the completion of the application. The sign shall be sufficient if it meets the following minimum specifications:

- ~~A.~~a. The sign must be at least five (5) inches wide and four (4) inches high;
- ~~B.~~b. The sign must be made of rigid, weather resistant material that will last at least forty-eight (48) hours when placed outdoors;
- ~~C.~~c. The sign must be light colored (white, beige, yellow or pink) with dark, bold letters (black, blue or green);
- ~~D.~~d. The sign must bear:
 - ~~1.~~i. the word CAUTION in 72 point type;
 - ~~2.~~ii. the words PESTICIDE APPLICATION in 30 point type or larger;
 - ~~3.~~iii. the Board designated symbol;

- ~~4~~.iv. any reentry precautions from the pesticide labeling;
- ~~5~~.v. the name of the company making the pesticide application and its telephone number;
- ~~6~~.vi. the date and time of the application; and
- ~~7~~.vii. a date and/or time to remove the sign.

E.C. **Exemption from this section**

1. The placement of marked bait stations in outdoor settings shall be exempt from this section.
 2. Any person providing notice in accordance with Chapter 51 - Notice of Aerial Pesticide Applications, Section III. - Ornamental Plant Applications, shall be exempt from this section.
-

STATUTORY AUTHORITY: 22 MRSA §1471-M(2)D

EFFECTIVE DATE:

September 22, 1998

AMENDED:

April 27, 1999

June 26, 2000

March 4, 2007 – Section 1(B)(e), filing 2007-68

December 26, 2011 – filing 2011-473

CORRECTIONS:

February, 2014 – agency names, formatting

**BASIS STATEMENT FOR ADOPTION OF
CMR 01-026, CHAPTER 28—NOTIFICATION PROVISIONS FOR OUTDOOR
PESTICIDE APPLICATIONS**

Basis Statement

Chapter 28 requires applicators to post certain types of treatments commonly made in residential areas instead of identifying sensitive areas under Chapter 22. In recent years, the Board observed that there are now a couple of other types of common residential applications: ticks and mosquitoes (licensing category 7E) and certain types of vegetation management applications made under licensing category 6B (except trails and sidewalks). Consequently, the Board proposed adding these types of applications to the list of licensing categories that require posting.

Applications for rights-of-way vegetation management are routinely given variances from the Chapter 22 requirement to map sensitive areas provided the applicator publishes notice in a newspaper and implements a drift management plan. The Board felt it made sense to put these requirements in rule, thus eliminating the necessity of applying for a variance every year. Consequently, the Board proposed adding to Chapter 28 the requirement for a newspaper notice for right-of-way spraying, including trails and sidewalks.

Comments received during the comment period observed that the proposal as written would now require newspaper notice for applications that have always been exempted from Chapter 22 (applications made with non-powered equipment) and therefore never had to identify sensitive areas. In addition, posting would now be required for certain types of vegetation management applications that are not residential in nature (power substations, which are fenced, and railroad sidings, which are not open to the public), which raised questions about the public benefit of the proposal.

The Board found that newspaper notices are expensive and of questionable value and determined that the public interest is best served by eliminating this requirement from the rule. However, the Board observed that there is often public interest in pesticide applications made to trails and sidewalks open to use by the public. The Board determined that the public interest is best served by requiring applicators to implement effective public notice method(s) based on a policy the Board would develop that allows various options tailored to specific circumstances.

Finally, the Board agreed that posting of power line substations and railroad sidings provided little public benefit. Consequently, in the final rule, the Board exempted applications to these sites from the requirement. After incorporating the changes outlined herein, based on the rulemaking record, the Board found the revised proposal is consistent with the public interest and voted to adopt the amendments.

Impact on Small Business

In accordance with 5 MRSA §8052, sub-§5-A, a statement of the impact on small business has been prepared. Information is available upon request from the Maine Board of Pesticides Control office, State House Station #28, Augusta, Maine 04333-0028, telephone 207-287-2731.

Provisional Adoption

At its October 24, 2014 meeting, the Board provisionally adopted the major substantive amendments to Chapter 28.

Legislative Approval

On February 24, 2015 the Joint Standing Committee on Agriculture, Conservation and Forestry (ACF) held a public hearing on LD 202, the resolve authorizing final adoption of the amendments. Subsequently the ACF reported the resolve out as ought-to-pass. The Legislature enacted the resolve and it became law as emergency legislation without the Governor's signature on March 29, 2015 (Resolve 2015, Chapter 6).

Rulemaking Statement of Impact on Small Business

5 MRSA §8052, sub-§5-A

Agency

Department of Agriculture, Conservation and Forestry—Maine Board of Pesticides Control

Chapter Number and Title of Rule

CMR 01-026, Chapter 28—Notification Provisions for Outdoor Pesticide Applications

Identification of the Types and an Estimate of the Number of the Small Businesses Subject to the Proposed Rule

The Board estimates that there are approximately 150 small businesses that perform residential and vegetation management applications that are affected by the proposed amendments

Projected Reporting, Record Keeping, and Other Administrative Costs Required for Compliance with the Proposed Rule, including the Type of Professional Skills Necessary for Preparation of the Report or Record

The proposed amendments will require companies making tick and biting fly applications, and certain vegetation management applications to post those applications. Signs cost about \$1.50 each and would likely take about five minutes to post. So the total cost per customer may be as high as \$4.00. However, many companies are already posting tick and biting fly treatments, and there is some company name recognition value to posting. Moreover, the additional cost of posting under the Chapter 28 amendments will be offset by the reduced administrative costs under Chapter 22 since applicators will no longer be required to identify and record sensitive areas.

In addition to the added posting requirements described above, the proposed amendments will require some form of public notification to treat sidewalks and trails open to use by the public. The method of notification would be based on a menu of options contained in Board policy. Municipalities and land trusts are often making similar efforts already. The Board decided against requiring costly newspaper notices in these circumstances, however, the administrative costs of the new notification methods may run as high as \$100 for pesticide applications to public sidewalks and trails.

Brief Statement of the Probable Impact on Affected Small Businesses

The proposed amendments to Chapter 28 may add nominal new posting and/or notification costs, but in many cases, the new costs will be offset by reduced administrative costs arising from Chapter 22, since the need to identify and record sensitive areas will be eliminated.

Description of Any Less Intrusive or Less Costly, Reasonable Alternative Methods of Achieving the Purposes of the Proposed Rule

Since there are no anticipated increased burdens on small businesses, there are no less intrusive or less costly alternatives.

SUMMARY OF COMMENTS—CHAPTERS 20, 22, 28, 31, 32, 33 AND 41—AUGUST 2014

PUBLIC HEARING, AUGUST 8, 2014

END OF COMMENT PERIOD, AUGUST 22, 2014

TESTIMONY AND WRITTEN COMMENTS RECEIVED			
Person/Affiliation	Summary of Testimony	Type of Comment	Board Response
Ted Quaday Maine Organic Farmers and Gardeners Association	Ch. 28 – Supports public notification of pesticide use. Questions the efficacy of newspaper notices. Suggests revisiting the automated web-based notification system discussed previously by the Board.	Written	28—Board agrees that newspapers may not be effective in reaching target audience. Amended rule to require public notice using methods approved in Board policy.
Darin Hammond Jasper Wyman & Son	Ch. 22 – The Board is asking companies to implement drift management plans when spraying under categories 6A and some aspects of 6B. Chapter 22 no longer references a drift management plan. Believes Ch. 22 adequately addresses drift management as it is.	Oral and written	22—Board agreed that the chapter as a whole addresses drift adequately. Amended rule to remove requirement for implementing a drift management plan.
Nicolas Hahn, Gerry Mirabile Central Maine Power Company	Ch. 22 – Support exempting category 6B from the requirement to identify sensitive areas. Ch. 28 – Believe posting of substations is unnecessary and excessive for substations since access is restricted anyway. Propose exempting restricted-access substations. Oppose publication of advance notice of category 6A applications since they are targeted applications made by non-powered equipment. Propose exempting utility ROWs.	Oral and written comments	28—Board agrees that public notification is not necessary for private ROWs; most of the questions arise from trails and sidewalks. Amended rule to require public notice only for 6B applications made to trails and sidewalks open to use by the public. Board agreed there was no value to posting substations and exempted substations in the final rule.
Chris Everest Commercial Applicator	Ch. 22 – Observes there are a lot of sensitive areas to identify for mosquito applications. Ch. 28 – Appreciates that the Board is willing to make changes that alleviate administrative burdens.	Written	Board agrees with comments.

SUMMARY OF COMMENTS—CHAPTERS 20, 22, 28, 31, 32, 33 AND 41—AUGUST 2014

PUBLIC HEARING, AUGUST 8, 2014

END OF COMMENT PERIOD, AUGUST 22, 2014

TESTIMONY AND WRITTEN COMMENTS RECEIVED			
Person/Affiliation	Summary of Testimony	Type of Comment	Board Response
Brian Chateauvert Railroad Weed Control	Ch. 28 – Posting of category 6B areas could be very difficult on the railroad sidings. These are large open areas where the public is normally not allowed.	Oral	28— Board agreed there was no value to posting railroad sidings and exempted railroad sidings in the final rule.
Chuck Cotton Lucas Tree Experts	Ch. 22– Supports changes as proposed. Ch. 28 – Observes that the proposed amendments to Ch. 28 include a new newspaper notification requirement for applications made under categories 6A and some aspects of 6B. [The Board has been requiring newspaper notification for variances from Ch. 22, but not for applications that do not require a variance (e.g. non-powered equipment).] Opposes the new requirement mainly because they do a lot of applications on small industrial or residential sites for which newspaper advertising would serve no purpose, might discourage some clients and would therefor damage their business.	Written	28—Board agrees that public notice does not serve a purpose in some instances, especially for 6A applications. Amended rule to require public notice using methods approved in Board policy and only for 6B applications made to trails and sidewalks open to use by the public.
Glenn Nadeau Emera Maine	Notes discrepancies in the category names as described in various Board rules. Ch. 28 – Clarifies that the proposal will now require newspaper notices for applications made under category 6A [The Board has been requiring newspaper notification for variances from Ch. 22, but not for applications that do not require a variance (e.g. non-powered equipment).].	Written	28— Board agrees that newspapers may not be effective in reaching target audience. Amended rule to require public notice using methods approved in Board policy and only for 6B applications made to trails and sidewalks open to use by the public.

SUMMARY OF COMMENTS—CHAPTERS 20, 22, 28, 31, 32, 33 AND 41—AUGUST 2014

PUBLIC HEARING, AUGUST 8, 2014

END OF COMMENT PERIOD, AUGUST 22, 2014

TESTIMONY AND WRITTEN COMMENTS RECEIVED			
Person/Affiliation	Summary of Testimony	Type of Comment	Board Response
Mark Lamberton Emera Maine	Ch. 28 – Observes that the proposed amendments to Ch. 28 include a new newspaper notification requirement for applications made under categories 6A and some aspects of 6B. [The Board has been requiring newspaper notification for variances from Ch. 22, but not for applications that do not require a variance (e.g. non-powered equipment).] Questions the efficacy of newspaper notices. Notes that utility lines are linear and therefor cross through many towns and are often remote, making them difficult to describe in a way that is meaningful to the public. Additional newspaper and posting requirements would be a financial burden. Proposes exempting category 6A from the newspaper notification and suggests that utility companies include vegetation management information on the company website.	Written	28—Board agrees that newspapers may not be effective in reaching target audience. Board agrees that public notification about applications made to private ROWs is unnecessary; most of the questions arise from trails and sidewalks. Amended rule to require public notice using methods approved in Board policy and only for 6B applications made to trails and sidewalks open to use by the public.



PAUL R. LEPAGE
GOVERNOR

STATE OF MAINE
DEPARTMENT OF AGRICULTURE, CONSERVATION AND FORESTRY
BOARD OF PESTICIDES CONTROL
28 STATE HOUSE STATION
AUGUSTA, MAINE 04333-0028

WALTER E. WHITCOMB
COMMISSIONER

HENRY S. JENNINGS
DIRECTOR

MEMORANDUM

Date: April 15, 2015
To: Board Members
From: Henry Jennings
Subject: Criteria for Issuing Variances from Chapter 29, Section 6 for Railroad Spraying

Companies spraying railroads need to obtain variances from Chapter 29, Section 6 if they wish to make broadcast applications of herbicides within 25 feet of surface water. Railroad companies have traditionally requested to apply herbicides up to 10 feet of water crossings.

Historically, the Board has granted variances for railroad spraying provided that the applicant adheres to the "MDOT model." At the May 16, 2014, meeting the Board granted a one-year variance from Chapter 29 to Asplundh Tree Expert Company—Railroad Division. However, concern was voiced at the meeting about the runoff potential for one of the herbicides listed on the application. Those present came to the realization that no one was completely sure what the "MDOT model" entailed. Consequently, the Board directed the staff to work with MDOT and other experts to develop guidelines/criteria for the issuance of railroad variances prior to next season. Robert Moosmann of MDOT has developed some draft guidelines (attached) and the staff has been researching the available railroad spraying guidelines and the products commonly used.

After considering the purpose of the requirement for which Chapter 29 variances are issued, contemplating the Board's directive, and reviewing related material, the staff came to the conclusion that the principal question relates to the inherent runoff risks related to the product choices. Based on this premise, it led the staff to two possible paths: 1) conduct comprehensive comparative aquatic risk assessments on each of the potential products, or 2) rely on EPA's assessment by way of the surface water advisory statements on the product labels. Given that the staff is currently engaged in a rather ambitious assessment of pesticide risks to marine invertebrates, the latter option appears to be the more prudent choice.

The staff has excerpted the surface water advisories (attached) from the products containing the active ingredients used on last year's projects. A rather wide diversity in the level of concern in the advisories is quickly apparent. The water quality advisories reveal there is relatively little concern for glyphosate and imazapyr products. The Dupont Oust Extra (sulfometuron methyl and metsulfuron methyl) label contains a 25 foot buffer to surface water for railroad applications thereby precluding the Board from issuing a variance for that product. Labels for products containing aminopyralid (e.g. Chaparral), aminocyclopyrachlor (e.g. Streamline) and indaziflam (e.g. Esplande) all include surface water advisories that raise concerns. The staff would like guidance from the Board on whether products with these advisories should qualify for a variance.

In addition to screening for appropriate products for variance consideration, Bob Moosmann has identified a series of criteria the Board may want to consider as requirements for issuing variances for spraying within 25 feet of surface water, such as:

- Requiring the use of products that do not contain surfactants
- Requiring inclusion of a sticker/extender (like pineolene) for which there is scientific data supporting the ability of the adjuvant to adhere the herbicides to the substrate.
- Prohibiting—consistent with some of the ground water advisories—applications when significant precipitation is forecast for the application area within 24 hours
- Considering the time of year when spraying will be conducted. MDOT discourages railroad applications in May or June as these have been very wet months in recent years.

Recommendations for Herbicide Use in State of Maine Owned Railroad Rights-of-Way

Introduction

The State of Maine owns approximately half of all railroad rights-of-way in Maine. This represents about 600 miles of track and contains single track line, multiple track lines, sidings, bridges, signaled crossings, switching yards, and building structures. Historically, rail lines were constructed on gentle grades, many of which are adjacent to rivers and lakes. Rail lines also cross numerous streams and rivers, both permanent and intermittent, and run through or adjacent to a variety of wetland habitats. In some cases, rail may also run near or across surface water public drinking water supplies or near public drinking water wells. These locations adjacent to valued natural resources, as well as communities and businesses that rail passes through and serves, make the job of maintaining vegetation of critical importance not only to ensure safe operation but also in the choices associated with management of vegetation.

In the modern era, vegetation managers have moved toward the use of herbicides as a key component in the management of railroad rights-of-way. While the use of herbicides may be controversial for some, there is much evidence that proper use of herbicides has lower environmental impact than other methods for control of vegetation. Experiments have been conducted around the world in alternative methods for control of vegetation in railroad rights-of-way. They include the use of steam, infrared radiation, mechanical disturbance, hand labor, mechanical brush removal, controlled burn, open flame burning, hot water, weed barrier, vacuum clearing, freezing, electro-thermal, ultraviolet light, and establishment of monoculture crops such as low growing grass or clover. Many of these methods are classified as short term solutions. In some cases, methods may stimulate vegetative growth, making them counterproductive. These methods are always more expensive than herbicide application and most require multiple re-treatment within the same growing season.

Herbicides represent a reasonable, efficient, cost-effective alternative. Typically treatments need only be done once a year or once every other year to maintain an adequate level of control. The concern for vegetation managers is determining the type of vegetation, vegetative pressure, what products to use, at what rates, adverse weather conditions, when to apply, how to apply, properly identifying risk to workers and the environment, and how to engage the public with information that addresses concerns and informs about products, procedures, and schedule. In addition, managers and applicators must be informed about state and local pesticide regulations, environmental fate for products used, mobility, potential groundwater contamination, and potential harmful health effects, both short and long term. Products that demonstrate carcinogenicity or mutagenicity should be avoided, for example.

For these reasons, understanding the vegetation, the environment, and choice of chemistries, formulas, and methods of application are the central concern and a protocol for decision making needs to be in place. The recommendations that follow are intended to provide a format when making decisions and establishing protocol for the use of herbicides in State of Maine owned railroad rights-of-way managed by the Maine Department of Transportation.

Choice of Chemistries

Decisions about which herbicide products to use should begin with an understanding of the vegetation that needs to be controlled and the amount of vegetation, often referred as stem density. Vegetation may include hardwood and softwood trees, grasses, and annual and perennial weeds. Railroad rights-of-way can be divided into three main components. They are the track and railroad ties, the ballast zone, and the area from the ballast zone to the edge of the right-of-way.

The track and railroad ties that track are attached to comprise an eight to ten foot width. This zone should be free of vegetation to allow for ease of inspection of the infrastructure. The Federal Transportation Board requires that the infrastructure be inspected on a regular schedule, typically once every two weeks regardless of whether the line is active or inactive. Any vegetation growing in and around the rail and ties makes inspection difficult. Breaks and cracks in the rail may go unnoticed, spikes used to attach the rail to the ties may be loose or missing, and couplings may break or loosen. Obscuring vegetation may make these defects more difficult to see. If these defects go unnoticed and unrepaired, the issues may cause trains to derail. Switches, electric boxes, crossing lights and gates may all become inoperable when defects cannot be detected due to obscuring vegetation. The consequences from improper inspection and timely repair can be dramatic and include derailment, car and train collisions, train and large animal collisions, and even loss of life. Vegetation in railroad rights-of-way may also catch on fire. Fire starts may spread beyond the right-of-way into high value properties with dramatic consequences.

The ballast zone typically includes the track and railroad ties and extends out to include the ballast that the track is constructed on. The width of the ballast zone is approximately 20 feet, 10 feet in either direction from the track centerline. The ballast zone provides a stable base for the track and ties and should be well drained material such as 1 to 2 inch sub angular stone. Historically, rail companies used spent coal as a base under the ballast. It was a by-product from burning coal to run steam locomotives. Fly ash may have also been deposited in track construction. This sub-base can be relatively impermeable and may help to prevent herbicides that may otherwise be mobile from percolating down through the soil profile in the ballast zone and potentially into groundwater. The 20 foot ballast zone should also be free of vegetation to allow for proper drainage.

The third zone from edge of ballast to edge of right-of-way presents different challenges for vegetation managers. Active trains, whether passenger or freight, cannot have trees capable of hitting the train. The third zone needs to be free of trees and tree branches that would interfere. State of Maine rail lines can be active or inactive. In either case, they should be treated as if trains would run on them and there should be no trees capable of hitting a train in the third zone. A typical railroad right of way is 66 feet wide, or 33 feet in either direction from the centerline of the track. The tree-free zone typically measures 50 feet, or 25 feet in either direction from centerline.

For simplicity we can call the 8 to 10 foot track and tie zone, Zone 1; the ballast zone, Zone 2; and the remaining portion of the right-of-way, Zone 3.

Zone 1

It is important that Zone 1 be kept free of all vegetation. This includes trees, weeds, and grasses. Therefore, chemistries chosen for control of vegetation in Zone 1 may differ from the other two zones. Choice may include non-selective as well as selective herbicides. It is important to note that choice may also be influenced by how different selective and non-selective herbicides work in synergy with each other. Using a combination of herbicides that have different modes of action increases efficacy and allows individual herbicides in the combination to be used at lower rates than required if each herbicide is used alone.

Herbicides work by interrupting or reducing various metabolic functions in plants. They may affect cell growth by slowing down or speeding up cell division as is the case with metsulfuron methyl and triclopyr respectively, for example. Or, in the case of non-selective glyphosate, the herbicide shuts down a key process of amino acid synthesis essential to sustain life in the plant. Simply put, a given herbicide is designed to disrupt a process in the plant that may result in eventual death. Understanding the mode of action of herbicides is a good starting point to determine how to use them together to successfully kill the target plants in question.

Zone 1 may contain hardwood and softwood tree species as well as grasses and weeds. Any zone within railroad rights-of-way may also have unique invasive species that may require a different approach to control. It is useful to choose several different chemistries when trying to control the combination of trees, weeds, and grasses. Not only is mode of action important to consider, but the persistence and ability to be root absorbed may also enter into the decision.

Some products such as aminocyclopyrachlor, aminopyralid, diuron, metsulfuron methyl, sulfometuron methyl, clopyralid, dicamba, imazapyr, and picloram have some degree of persistence in soil and some may be absorbed through the roots of plants. This behavior is often referred to as being "soil active". While this is beneficial for controlling plants, it may also present risks. This list of products exhibits some degree of persistence, may have potential to leach through the soil profile over time, or may injure non-target plants through root uptake.

It is useful to choose from among this group of products to provide for residual control, however the length of time a product persists, how much is applied per unit, and how leachable it is must be weighed when deciding what product or products are suitable. For example, diuron is not a suitable choice since it may persist for more than a year in Maine soils and has shown up in groundwater sampling nationally. Repeat treatments year to year may result in an increase in the amount of product in the soil and may increase potential groundwater contamination. It should be noted that leaching potential increases with an increase in application rate.

In contrast, of the products mentioned above, the sulfonylurea herbicides metsulfuron methyl and sulfometuron methyl have relatively short persistence in soils and a moderate to low risk of leaching when used at lower rates. This makes them a good choice when persistence and leaching are a concern.

It may be useful to use a non-selective herbicide as part of a combination of products to provide a wider range of control across species. For example, the presence of hardwood and softwood trees will require a product or combination of products that can provide control of them. Most sites will have weeds and grasses. Grasses can only be controlled with non-selective herbicide such as glyphosate, imazapyr, or higher rates of the sulfonylurea's, while weeds are typically easily controlled with selective herbicides

such as triclopyr. When choosing a chemical combination for the control of trees, weeds, and grasses herbicides that can impact 2 or 3 of these plant types are preferred over herbicides that only impact a limited group of plants. Imazapyr, for example, is effective at lower rates of 8 to 16 ounces per acre and in combination with other products such as glyphosate, metsulfuron methyl and sulfometuron methyl when grasses and weeds are the target. However, when hardwood and softwood trees are present the rate of imazapyr may be more effective at 16 to 32 ounces per acre and in combination with other products.

In recent years there has been some interest in using aminocyclopyrachlor or aminopyralid as a substitute for imazapyr for selective control of weeds. Both products are soil active and aminocyclopyrachlor is especially harmful to pine and spruce when taken up through the roots. Even lower rates of aminocyclopyrachlor such as 6 ounces per acre may cause severe injury or death to non-target pine or spruce. Recent work by the Department in trials of aminocyclopyrachlor for guardrail application showed excellent control of broadleaf weeds at a rate of 4 ½ ounces per acre. Imprelis[®], a product containing aminocyclopyrachlor, was removed from the market within several years of registration. It was registered for use on broadleaf weeds in turf at a rate of 4 ½ ounce per acre and proved to be highly injurious to non-target pine and spruce at that rate.

Since this new class of chemistry, the pyrimidine carboxylic acid group, can be highly mobile and injurious to non-target plants, use rates should be kept as low as possible. Experiments need to be conducted to see if this class of chemistry may be of benefit in combination with other products at rates lower than 4 ½ ounces per acre. The Department will conduct limited experiments with lower rates to determine if the product has use in rights-of-way application in Maine. For now, the Department will not experiment with aminocyclopyrachlor for railroad application.

The sulfonylurea's, metsulfuron methyl and sulfometuron methyl, have the qualities of selective herbicides when used at very low rates but display non-selective characteristics at higher rates. Glyphosate, considered non-selective, may not adequately control some tree species at lower rates of ½ to 2% solutions, but increased to 5 to 10% solutions will kill all species. Imazapyr has a unique mode of action, entering the plant and moving to meristematic growth points, and is effective at controlling new growth at low rates. It will also move into and store in the root system and move outward the following season. This impact may be seen over several seasons in trees and result in eventual death of the plant.

The first step in deciding what herbicides to use in Zone 1 is determining what vegetation requires control, and then deciding what concentrations will eliminate the vegetation. For example, if there are no trees in Zone 1 imazapyr does not need be part of the mix. Using a combination of glyphosate, metsulfuron methyl and sulfometuron methyl should control the weeds and grasses and provide a residual level of control for up to a month or more. Choose the lowest rates possible for the desired results. Active rail will require yearly applications in Zone 1, however inactive rail may not. Decisions should be made based on field observation.

Zone 2

Zone 2 does not differ greatly from Zone 1 in the need to keep the zone free of vegetation. However, the reasons for a vegetation free Zone 2 are different from the reasons for a vegetation free Zone 1. No trees should be allowed to grow in Zone 2 and this is best accomplished with herbicide application before trees grow beyond the legal height limits for application as set forth in Maine pesticide regulation. Due to the height restrictions for foliar spraying of six feet for hardwood and three feet for softwood, applications should be scheduled every year or no more than every other year based on field

observation. Ballast material should be free draining; therefore controlling vegetation on a regular schedule will help prevent buildup of organic matter from plant decomposition. Using a combination of imazapyr, glyphosate, metsulfuron methyl and sulfometuron methyl should control trees, weeds and grasses and provide a residual level of control for up to a month or more. Choose the lowest rates possible for the desired results. Active rail will require yearly applications in Zone 2, however inactive rail may not. Decisions should be made based on field observation.

Zone 3

Vegetation in Zone 3 may be allowed to grow, however trees may need to be removed periodically and some weeds and grasses may be problematic if they create flammable material. If large trees in Zone 3 begin to encroach into the area of operation they need to be removed mechanically. Untreated hardwood stumps will re-sprout. Spraying re-sprout may not prevent future re-sprouting, making re-treatment necessary.

Recent research by the Department shows that a combination of imazapyr and fosamine ammonium may be more effective at keeping a stump from re-sprouting than traditional. Fosamine ammonium moves to meristematic growth points (next year's leaf buds) and prevents leaf sprouting the season after treatment. Imazapyr stores in the roots and moves out to the same meristematic growth points the following season, but may also move through new shoots developed from epicormic or adventitious growth. A stump treatment of the cut surface and root flare within 24-48 hours after cutting would provide the best control of re-sprout, however this is impractical when mechanical removal of brush is done in railroad rights-of-way due to the large number of stumps over a large clearing area. The periodic cost of mechanical tree removal and follow-up herbicide treatments to control re-sprouting stumps needs to be weighed against the cost of a more rigorous approach to vegetation control using herbicides. Typically, regularly scheduled treatments of vegetation in Zone 3 with herbicides is dramatically less expensive than waiting until trees are larger and require mechanical removal.

Active rail demands a more cost effective approach to dealing with vegetation in Zone 3 than inactive rail. Vegetation in Zone 3 on active rail should be controlled with herbicides on a regular basis to prevent buildup of flammable material, prevent trees from growing beyond the point that herbicide can be applied legally, and to provide a safety clear zone for overall operation. Zone 3 may be less well managed on inactive rail, however budget may dictate that a schedule be established and maintained rather than letting this section grow out of control.

Another alternative for Zone 3 is side branch trimming with herbicide. The only product legally allowed in Maine for side branch trimming is fosamine ammonium. Any branch with foliage sprayed will die back. Fosamine ammonium only moves outward and therefore cannot negatively impact the tree but will kill branches that may interfere with rail operation. This product is prohibitively expensive, but may be considered as an alternative to mechanical removal.

Other Considerations

Many of the herbicides in current use on rail in the United States and in Maine demonstrate some degree of mobility, both in lateral movement across the surface of the right-of-way and also for movement through the soil profile and potentially to groundwater. Manufacturers of pesticide products have long promoted the use of additives, also called adjuvants, which enhance performance by improving the spread of products across leaf surfaces or that increase absorption into leaf tissue. Non-ionic surfactants are among the typical adjuvants recommended for use. Many products sold commercially contain surfactant added by the manufacturer. Surfactants are useful, however they have

proven to cause issues in rail applications. Simply put, surfactants are soaps and experience has shown they increase the potential for herbicide products to move laterally and potentially through the soil profile. The Department has sought out alternatives and beginning in 2006 no longer use products containing surfactants and no longer use surfactants in spray formulas.

A better alternative is now being used that has proven to help keep herbicides in place for up to 3 to 4 weeks. The material is pinolene. Several manufacturers provide products with this active ingredient. It is considered a sticker-spreader-extender and helps to encapsulate pesticides, gluing them to plants, or to the ground. Typically these products make pesticide applications rain-fast within 30 minutes, reducing the potential for lateral movement and movement through the soil profile.

In the past, when rain occurred shortly after application and with surfactants in the mix, plant control was compromised and re-treatment was necessary to control vegetation. Not only was this wasting time and money but more products would be applied increasing the application rate in a given re-treated area. The use of a spreader extender has dramatically reduced movement, eliminated call backs, and improved control of vegetation.

Some herbicide products are volatile, transforming to a gaseous state after application when temperatures rise. Products that display volatile characteristics should be avoided. Volatile products may also have a significant objectionable odor. The gaseous portion is susceptible to moving off target, in some atmospheric conditions miles from the target. This gaseous portion can cause damage to crops, landscape plants, and other non-target vegetation creating potential liability.

Conclusions

- Herbicides are a useful, cost effective, and environmentally friendly tool for managing vegetation in railroad rights-of-way when applied properly.
- Herbicide choice is important. Non-volatile, less persistent, non-carcinogenic, non-mutagenic products should be chosen.
- Products that have less risk of lateral movement or movement through soil profiles should be used.
- Understanding mode of action is a good first step in choosing products and should be understood when combining products to achieve a wider range of control across species.
- Using different products in combination, which have differing modes of action, provides a synergy not possible when using one product alone.
- This synergy allows for each product to be used at lower application rates than if used alone.
- Products used in combination should be used at the lowest possible rates that achieve the desired results.
- Application rate, not only the amount of material applied per acre but the amount of water used per acre, can impact efficacy. Low volume application is more effective than high volume application since more products will stay in place on the plant and on the ground.
- Surfactants and products containing surfactants should be avoided.
- Adjuvants containing pinolene are recommended to stick herbicides to plants and ground surfaces, reduce potential for movement, eliminate callbacks, and improve efficacy.

This is an excerpt from the federal Streamline label, EPA Registration No. 352-848. Turn to the next page for selected information highlighting surface water hazards and precautions as indicated on the federal label. The complete label can be found on the National Pesticide Information Retrieval System (NPIRS) which can be linked to through the BPC website.

DuPont™ Streamline®

HERBICIDE

DO NOT USE PLANT MATERIAL TREATED WITH DUPONT™ STREAMLINE® FOR MULCH OR COMPOST

Dry Flowable

For Non-Crop Use

Active Ingredients

By Weight

Aminocyclopyrachlor 6-Amino-5-chloro-2-cyclopropyl-4-pyrimidinecarboxylic acid	39.5%
Metsulfuron methyl Methyl 2-[[[(4-methoxy-6-methyl-1,3,5-triazin-2-yl)amino]carbonyl]amino]sulfonyl]benzoate	12.6%
Other Ingredients	47.9%
TOTAL	100.0%

EPA Reg. No. 352-848

EPA Est. No. _____

Nonrefillable Container

Net: _____

OR

Refillable Container

Net: _____

E. I. duPont de Nemours and Company

1007 Market Street

Wilmington, DE 19898

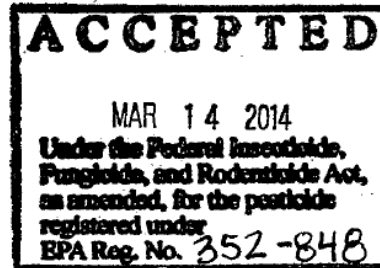

KEEP OUT OF REACH OF CHILDREN

CAUTION

Si usted no entiende la etiqueta, busque a alguien para que se la explique a usted en detalle. (If you do not understand this label, find someone to explain it to you in detail.)

FIRST AID

IF IN EYES: Hold eye open and rinse slowly and gently with water for 15-20 minutes. Remove contact lenses, if present, after the first 5 minutes, then continue rinsing eye. Call a poison control center or doctor for treatment advice.

IF ON SKIN OR CLOTHING: Take off contaminated clothing. Rinse skin immediately with plenty of water for 15-20 minutes. Call a poison control center or doctor for further treatment advice.

Have the product container or label with you when calling a poison control center or doctor, or going for treatment. You may also contact 1-800-441-3637 for emergency medical treatment information.

PRECAUTIONARY STATEMENTS

HAZARDS TO HUMANS AND DOMESTIC ANIMALS

Causes moderate eye irritation. Harmful if absorbed through skin. Avoid contact with skin, eyes, or clothing.

USER SAFETY RECOMMENDATIONS

USERS SHOULD: Wash thoroughly with soap and water after handling and before eating, drinking, chewing gum, using tobacco or using the toilet. Remove clothing/PPE immediately if pesticide gets inside. Then wash thoroughly and put on clean clothing.

Streamline, cont.

ENVIRONMENTAL HAZARDS

Surface Water Advisory

This product may impact surface water quality due to runoff of rain water. This is especially true for poorly draining soils and soils with shallow ground water. This product is classified as having high potential for reaching surface water via runoff for several months after application. A level, well-maintained vegetative buffer strip between areas to which this product is applied and surface water features such as ponds, streams, and springs will reduce the potential loading of aminocyclopyrachlor from runoff water and sediment. Runoff of this product will be reduced by avoiding applications when rainfall is forecasted to occur within 48 hours.

IMPORTANT RESTRICTIONS

- Do not make applications when circumstances favor movement from treatment site.
- Do not apply STREAMLINE® to roadsides or other non-crop areas during periods of intense rainfall, or where prevailing soils are either saturated with water or of a type through which rainfall will not readily penetrate, as this may result in off-site movement.

Esplanade, cont.

ENVIRONMENTAL HAZARDS

This Product is toxic to fish, aquatic invertebrates, and plants. Do not apply directly to water, or to areas where surface water is present or to intertidal areas below the mean watermark. Do not contaminate water when disposing of rinsate or washwater. This product may impact water through spray drift or runoff. Follow directions for use to avoid spray drift and runoff. A level well maintained vegetative buffer strip between areas to which this product is applied and surface water features including ponds, streams, and springs will reduce the potential of this product entering water from rainfall runoff. Runoff of this product will be reduced by avoiding applications when rainfall is forecasted to occur within 48 hours.

Surface Water Advisory: This pesticide may impact water quality due to runoff of rainwater. This is especially true for poorly draining soils and soils with shallow ground water. This product is classified as having a high potential for reaching surface water via runoff for several months or more after application.

USE PRECAUTIONS

- Applications made to areas where runoff water flows onto agricultural land may injure crops.
- Applications made during periods of intense rainfall, to soils saturated with water, or soils through which rainfall will not readily penetrate may result in runoff and movement of Esplanade 200 SC.
- Treated soil should be left undisturbed to reduce the potential for Esplanade 200 SC movement by soil erosion, by wind, or water.
- Applications should be made only when there is little or no risk of spray drift or movement of applied product into sensitive areas. Sensitive areas are defined as bodies of water (ponds, lakes, rivers, and streams), habitats of endangered species and non-labeled agricultural crop areas. Refer to the Spray Drift Management section of this label for more details.

APPLICATION INFORMATION

When spraying close or next to ponds, lakes, rivers, and streams be cognizant of keeping the spray solution from reaching the water.

This is an excerpt from the federal Oust Extra label, EPA Registration No. 352-622. Turn to the next page for selected information highlighting surface water hazards and precautions as indicated on the federal label. The complete label can be found on the National Pesticide Information Retrieval System (NPIRS) which is linked to through the BPC website.



DuPont™ Oust® Extra

herbicide

Dispersible Granules

<i>Active Ingredient</i>	<i>By Weight</i>
Sulfometuron methyl {Methyl 2-[[[(4,6-dimethyl-2-pyrimidinyl)amino]-carbonyl]amino]sulfonyl]benzoate}	56.25%
Metsulfuron methyl Methyl 2-[[[(4-methoxy-6-methyl-1,3,5-triazin-2-yl)amino]-carbonyl]amino]sulfonyl]benzoate	15.00%
Other Ingredients	28.75%
TOTAL	100%

EPA Reg. No. 352-622 EPA Est. No. _____

Nonrefillable Container

Net: _____

OR

Refillable Container

Net: _____

E. I. duPont de Nemours and Company
1007 Market Street
Wilmington, DE 19898

KEEP OUT OF REACH OF CHILDREN

CAUTION

Si usted no entiende la etiqueta, busque a alguien para que se la explique a usted en detalle. (If you do not understand this label, find someone to explain it to you in detail.)

FIRST AID

IF ON SKIN OR CLOTHING: Take off contaminated clothing. Rinse skin immediately with plenty of water for 15-20 minutes. Call a poison control center or doctor for further treatment advice.

IF IN EYES: Hold eye open and rinse slowly and gently with water for 15-20 minutes. Remove contact lenses, if present, after the first five minutes, then continue rinsing eye. Call a poison control center or doctor for treatment advice.

Have the product container label with you when calling a poison control center or doctor, or going for treatment. You may also contact 1-800-441-3637 for emergency medical treatment information.

PRECAUTIONARY STATEMENTS

HAZARDS TO HUMANS AND DOMESTIC ANIMALS

CAUTION! Harmful if absorbed through skin. Causes moderate eye irritation. Avoid contact with skin, eyes, or clothing.

PERSONAL PROTECTIVE EQUIPMENT (PPE)

Some materials that are chemical-resistant to this product are polyethylene and polyvinylchloride. If you want more options, follow the instructions for category A on an EPA chemical-resistant category selection chart.

All mixers, loaders applicators and other handlers must wear:

- Long-sleeved shirt and long pants.
- Shoes plus socks.

Follow manufacturer's instructions for cleaning/maintaining PPE. If no such instructions for washables exist, use detergent and hot water. Keep and wash PPE separately from other laundry.

Discard clothing and other absorbent materials that have been drenched or heavily contaminated with this product's concentrate. Do not reuse them.

Engineering Control Statement: Pilots must use an enclosed cockpit that meets the requirements listed in the Worker Protection Standard (WPS) for agricultural pesticides [40CFR 170.240(d)(6)].

When handlers use closed systems, enclosed cabs, or aircraft in a manner that meets the requirements listed in Worker Protection Standard (WPS) for agricultural pesticides [40 CFR 170.240 (d) (4-6)], the handler PPE requirements may be reduced or modified as specified in the WPS.

USER SAFETY RECOMMENDATIONS

USERS SHOULD: Wash hands before eating, drinking, chewing gum, using tobacco or using the toilet.

Remove PPE immediately after handling this product. Wash the outside of gloves before removing. As soon as possible, wash thoroughly and change into clean clothing.

Remove clothing/PPE immediately if pesticide gets inside. Then wash thoroughly and put on clean clothing. If no such instructions for washables exist, use detergent and hot water.

ENVIRONMENTAL HAZARDS

For terrestrial uses, except under the forest canopy, do not apply directly to water, or to areas where surface water is present, or to intertidal areas below the mean high water mark. Do not contaminate water by cleaning of equipment or disposal of equipment washwaters or rinsate.

This herbicide is injurious to plants at extremely low concentrations. Nontarget plants may be adversely effected from drift and run-off.

Exposure to OUST® EXTRA can injure or kill plants. Damage to susceptible plants can occur when soil particles are blown or washed off target onto cropland.

GROUND APPLICATIONS

- When applying liquid sprays the following directional buffers are required to protect aquatic vegetation in sites (including lakes, reservoirs, rivers, streams, marshes, ponds, estuaries, commercial fish ponds), or water used as an irrigation source, or crops.

50 feet - All broadcast applications other than railroad and roadside rights-of-way.

25 feet - Broadcast applications to railroad and roadside rights-of-way.

15 feet - All handheld spot treatment applications.

This is an excerpt from the federal Opensight (Chaparral) label, EPA Registration No. 62719-597. Turn to the next page for selected information highlighting surface water hazards and precautions as indicated on the federal label. The complete label can be found on the National Pesticide Information Retrieval System (NPIRS) which can be linked to through the BPC website

Q1J / Chaparral / MSTR Amend / 04-09-14

Page 1

[Sub-Label A for Range and Pasture]

(Base label):

Chaparral™

SPECIALTY HERBICIDE

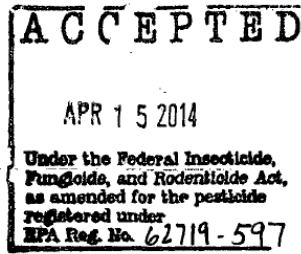

For control of susceptible weeds and certain woody plants, including invasive and noxious weeds, on rangeland, permanent grass pastures (including grasses grown for hay*), most warm-season grasses grown for hay*, Conservation Reserve Program (CRP) acres, non-cropland areas including industrial sites, rights-of-way (such as roadsides, electric utility and communication transmission lines, pipelines, and railroads), non-irrigation ditch banks, natural areas (such as wildlife management areas, wildlife openings, wildlife habitats, recreation areas, campgrounds, trailheads and trails), and grazed areas in and around these sites.

*Hay from grass treated with Chaparral within the preceding 18-months can only be used on the farm or ranch where the product is applied unless allowed by supplemental labeling

<p>IMPORTANT USE PRECAUTIONS AND RESTRICTIONS TO PREVENT INJURY TO DESIRABLE PLANTS</p> <ul style="list-style-type: none"> • Carefully read the section "Restrictions in Hay or Manure Use" • It is mandatory to follow the "Use Precautions and Restrictions" section of this label. • Manure and urine from animals consuming grass or hay treated with this product may contain enough aminopyralid to cause injury to sensitive broadleaf plants. • Hay can only be used on the farm or ranch where product is applied unless allowed by supplemental labeling. • Consult with a Dow AgroSciences representative if you do not understand the "Use Precautions and Restrictions". Call [1-(800) 263-1196] Customer Information Group. 	<p>Forage and Manure Management</p> <p>Rangeland, Pasture, Hayfield, CRP</p> <p>Manure, Hay, Bedding</p> <p>Compost</p> <p>Rangeland, Pasture, Wheat, CRP, Corn</p> <p>Potato, Lettuce, Beans, Tomato, etc.</p> <p>© Copyright 2011 Dow AgroSciences LLC</p>
---	---

Not For Sale, Distribution, or Use in New York State.

Opensight, cont.

GROUP	2	4	HERBICIDE
-------	---	---	-----------

Active Ingredients:

Potassium salt of 2-pyridine carboxylic acid, 4-amino-3,6-dichloro-	62.13%
Metsulfuron methyl (Methyl 2-[[[(4-methoxy-6- methyl-1,3,5- triazin-2-yl)-amino]carbonyl] amino]sulfonyl]benzoate)	9.45%
Other Ingredients	28.42%
Total	100.0%

Acid Equivalent: aminopyralid (2-pyridine carboxylic acid, 4-amino-3,6-dichloro-) - 52.5%

Contains 0.62 pound potassium salt of aminopyralid active ingredient (0.525 pound acid equivalent) and 0.0945 pound metsulfuron methyl per pound of product

Keep Out of Reach of Children

WARNING AVISO

Si usted no entiende la etiqueta, busque a alguien para que se la explique a usted en detalle. (If you do not understand the label, find someone to explain it to you in detail.)

Use Precautions and Restrictions

- Applications made during periods of intense rainfall, to soils saturated with water, surfaces paved with materials such as asphalt or concrete, or soils through which rainfall will not readily penetrate may result in runoff and movement of Chaparral. Injury to crops may result if treated soil and/or runoff water containing Chaparral is washed, or moved onto land used to produce crops. Exposure to Chaparral may injure or kill susceptible crops and other plants, such as grapes, soybeans, tobacco, sensitive ornamentals. Do not treat frozen soil where runoff could damage sensitive plants.

This is an excerpt from the federal AquaNeat label, EPA Registration No. 228-365. Turn to the next page for selected information highlighting surface water hazards and precautions as indicated on the federal label. The complete label can be found on the National Pesticide Information Retrieval System (NPIRS) which can be linked to through the BPC website.

AQUANEAT

Aquatic Herbicide

FOR USE ON EMERGED AQUATIC WEEDS AND BRUSH IN AQUATIC SITES.
FOR USE IN FORESTRY (INCLUDING WEED CONTROL IN CHRISTMAS TREE PLANTATIONS),
RIGHTS-OF-WAY, HABITAT RESTORATION AREAS, NON-CROP AND OTHER LISTED
APPLICATION SITES.

ACTIVE INGREDIENT:

Glyphosate, N-(phosphonomethyl)glycine, in the form of its isopropylamine salt* 53.8%

OTHER INGREDIENTS: 46.2%

TOTAL: 100.0%

*Contains 648 grams per litre or 5.4 pounds per U.S. gallon of the active ingredient, glyphosate, in the form of its isopropylamine salt. Equivalent to 480 grams per litre or 4 pounds per U.S. gallon of the acid, glyphosate.

KEEP OUT OF REACH OF CHILDREN
CAUTION – PRECAUCION

Si usted no entiende la etiqueta, busque a alguien para que se la explique a usted en detalle.
(If you do not understand the label, find someone to explain it to you in detail.)

SEE INSIDE BOOKLET FOR FIRST AID AND ADDITIONAL PRECAUTIONARY STATEMENTS

For Chemical Spill, Leak, Fire, or Exposure, Call CHEMTREC (800) 424-9300
For Medical Emergencies Only, Call (877) 325-1840

NOTIFICATION

MAR 27 2014

EPA REG. NO. 228-365
EPA EST. NO.
NET CONTENTS: GALS

Manufactured For
NUFARM AMERICAS INC.
11901 S. AUSTIN AVE.
ALSIP, IL 60803

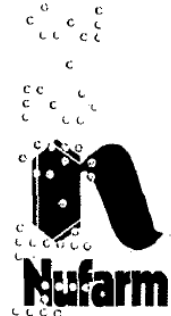

[Designation as "NONREFILLABLE" or "REFILLABLE" for containers > 5 GAL]
000228-00365.20140325.EPA Notification

AquaNeat, cont.

INDUSTRIAL, RECREATIONAL AND PUBLIC AREAS

Non-Crop Sites - This product may be used to control the listed weeds in terrestrial noncrop sites and/or in aquatic sites within these areas:

railroad rights-of way;

the sprayed plant followed by deterioration of both shoots and roots. This product has no herbicide activity in the soil and will not wash or leach to affect nearby vegetation. Any ornamental species may be planted in treated areas 7 days or more after application.

This is an excerpt from the federal Polaris AC Complete label, EPA Registration No. 228-570. Turn to the next page for selected information highlighting surface water hazards and precautions as indicated on the federal label. The complete label can be found on the National Pesticide Information Retrieval System (NPIRS) which can be linked to through the BPC website.

GROUP 2 HERBICIDE

Nufarm Polaris[®] AC Complete Herbicide

FOR THE CONTROL OF UNDESIRABLE VEGETATION IN FORESTRY SITES, AQUATIC SITES, GRASS PASTURE, RANGELAND, FENCE ROWS, FOR ESTABLISHMENT AND MAINTENANCE OF WILDLIFE OPENINGS, GRASS PASTURES AND RANGELAND.

ADDITIONALLY FOR CONTROL OF UNDESIRABLE VEGETATION IN DORMANT BERMUDAGRASS AND BAHIA GRASS, UNDER CERTAIN PAVED AREAS, AND INDUSTRIAL NONCROPLAND AREAS INCLUDING RAILROAD, UTILITY, PIPELINE AND HIGHWAY RIGHTS-OF-WAY, UTILITY PLANT SITES, PETROLEUM TANK FARMS, PUMPING INSTALLATIONS, STORAGE AREAS, BUILDING PERIMETERS, IRRIGATION AND NON-IRRIGATION DITCHBANKS, ROADS, TRANSMISSION LINES, AND INDUSTRIAL BARE GROUND AREAS.

ACTIVE INGREDIENT:

Isopropylamine salt of Imazapyr (2-[4,5-dihydro-4-methyl-4-(1-methylethyl)-5-oxo-1H-imidazol-2-yl]-3-pyridinecarboxylic acid)*

53.10%

OTHER INGREDIENTS:

46.90%

TOTAL: 100.00%

*Equivalent to 43.3% 2-[4,5-dihydro-4-methyl-4-(1-methylethyl)-5-oxo-1H-imidazol-2-yl]-3-pyridinecarboxylic acid or 4 pounds acid per gallon.

**KEEP OUT OF REACH OF CHILDREN
CAUTION / PRECAUCION**

Si usted no entiende la etiqueta, busque a alguien para que se la explique a usted en detalle.
(If you do not understand this label, find someone to explain it to you in detail.)

SEE INSIDE BOOKLET FOR FIRST AID AND ADDITIONAL PRECAUTIONARY STATEMENTS

For Chemical Spill, Leak, Fire, or Exposure, Call CHEMTREC (800) 424-9300
For Medical Emergencies Only, Call (877) 325-1840

In the State of New York, Aquatic Uses are Not Allowed.

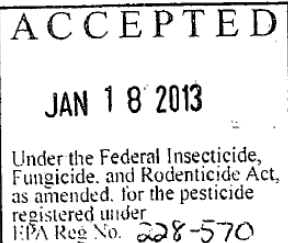

EPA REG. NO. 228-570
EPA EST. NO.

NET CONTENTS GALS.

MANUFACTURED FOR
NUFARM AMERICAS INC.
150 HARVESTER DRIVE
BURR RIDGE, IL 60527



[Designation as "NONREFILLABLE" or "REFILLABLE" for containers > 5 GAL]

000228-00570.20130117.EPA Amendment

Polaris AC Complete, cont.

ENVIRONMENTAL HAZARDS

This product is toxic to plants. Drift and run-off may be hazardous to plants in water adjacent to treated areas. Do not apply to water except as specified in this label. Treatment of aquatic weeds may result in oxygen depletion or loss to decomposition of dead plants.

Interim Guidelines for Forest Pesticide Applications

(Maine Board of Pesticides Control, Revised June 27, 2012)

The following interim guidelines describe techniques to avoid contaminating surface water and groundwater. These guidelines compliment local, state, and federal regulations governing the storage, handling and application of pesticides (herbicides, fungicides, insecticides). **These guidelines were not developed for and are not intended to serve as standards for permitting purposes.**

The land manager and/or applicator are expected to consider site specific conditions and adjust setbacks, methods, and materials to ensure that discharges of pesticides to surface waters of the state do not occur. **If the pesticide label also establishes setback requirements, the more stringent requirements apply.**

The Maine Board of Pesticides Control (BPC) water quality rule (CMR 01-026, Chapter 29) **prohibits broadcast application of pesticides within 25 feet of surface water. Only targeted, spot treatments are allowed within the setback.** In addition, the BPC drift rule (CMR 01-026, Chapter 22) establishes operational standards and thresholds for off-target drift.

General BMPs

In most cases, applications must only be conducted by MEBPC licensed applicators or USEPA Worker Protection Standard Pesticide Handlers.

1. Use a pesticide screening tool such as USDA-NRCS, WIN-PST program and choose effective products that exhibit the lowest combination of leaching potential, pesticide solution runoff potential, and pesticide adsorbed runoff potential.
2. Abide by all pesticide label requirements, including use rates, handling, storage, and disposal.
3. Conduct all pesticide handling—mixing, loading, equipment cleaning, and storage—on upland sites, away from water bodies, outside filter areas, and away from road drainage systems.
4. Maintain a spill containment and cleanup kit appropriate for the materials being applied.
5. Report all spills to the Maine Department of Environmental Protection and the Maine Board of Pesticides Control.
6. Store pesticides in a secure enclosure and maintain them at application sites only as long as necessary.

7. When practical, use product delivery technology that offers features such as a closed system and product tracking and allows for accurate premixed solutions. These technology options eliminate the need for open containers and triple rinsing and provide proper prescriptions without the need to use open pesticide containers.
8. Triple rinse pesticide containers. Recycle containers when possible or dispose of them through a solid waste facility when required.

Equipment

9. Rinse spray equipment and apply rinse water only in areas that are part of the application site.
10. Properly maintain and repair all equipment for leaking hoses, connections and nozzles.
11. Calibrate spray equipment to apply chemicals uniformly and in the correct quantities.

Sensitive Areas/Application

12. Develop and employ site treatment maps showing all sensitive areas, including surface waters with the appropriately applied buffers.
13. Only make spot treatment applications within 25 feet of surface waters for ground application.
14. Use spot-injection or stump treatments methods when applying chemicals not labeled for aquatic use in streamside management zones.
15. Direct spray applications away from surface waters when feasible.
16. Avoid spraying areas with standing water connected to a surface water.
17. Avoid applications to saturated soils.
18. Avoid applying herbicides in areas where the chemicals can injure stabilizing vegetation on slopes, gullies, and other fragile areas subject to erosion that drain into surface water.
19. Avoid applications close to steep slopes or drainage swales and other features that lead to surface waters potentially resulting in a discharge.
20. Avoid application to impervious surfaces, exposed bedrock, or frozen soils.

Weather/Drift Management

21. Apply pesticides only during favorable weather conditions.
 - a. Avoid applications prior to an expected heavy rainfall.
 - b. Avoid applications during periods of atmospheric inversion or fog.
 - c. Avoid application in high temp, low humidity conditions.
 - d. Whenever possible, only apply pesticides when wind conditions are between 2-10 mph.
22. Follow a drift management plan to prevent drift.
 - a. Maintain buffers between spray operations and water bodies.
 - b. Increase the buffer size when there is no vegetation in the buffer.
 - c. Use low-volatility pesticides when possible.
 - d. Spray when winds blow away from surface waters or have a monitor/spotter in full PPE to warn applicator if drift becomes an issue.
 - e. Select spray nozzles and pump pressures that produce the largest, efficacious droplet.
 - f. Add adjuvants to reduce spray drift when the pesticide label allows, unless not recommended by the University of Maine Cooperative Extension.

BMPs Specific to Aerial Applications

23. Ensure a drift management plan is available for inspection.
24. Use a minimum 75-100 foot spray buffer on all surface waters for aerial application.
25. Depict all sensitive areas and the appropriate buffers on paper maps to ensure adequate protection.
26. Supply pilots with individual site treatment maps for each treatment block prior to application.
27. Discuss each site with the pilot prior to application to ensure all sensitive areas are protected.
28. Use GIS created paper treatment maps and uploaded treatment maps in the onboard “real-time” GPS navigation system to ensure that the correct sites are being treated.
29. Pre-fly application sites to:
 - a. Ensure the digitized sites reflect the true nature of the treatment site.
 - b. Scout for surface water that might not be present on the paper site map provided to the pilot.
30. Use the AUTOCAL system to maintain proper GPA based on the speed of the aircraft.
31. Use Accu-Flo or other large droplet style nozzles for herbicide applications in order to produce the largest efficacious droplets with the narrowest size spectrum to minimize drift.
32. Configure application equipment to minimize wind shear of spray droplets.

33. Turn booms on and off at the appropriate time when entering or leaving a treatment block.
34. Avoid spraying directly on the downwind edge of a treatment block. Move the spray swath upwind from this edge, i.e., offset by 1/2 to 1 swath width.
35. Identify and avoid streamside management zones and surface water to prevent pesticides from drifting over open water or from accidentally being applied directly on the water. Avoid flying directly over surface waters while making applications.
36. Apply parallel to surface waters when feasible.
37. Employ all depicted buffers around all surface waters.
38. Fly treatment block edges that are next to surface waters when the wind is away from the surface waters.
39. Download post-application log files from the on-board GPS system showing the flight of the helicopter/aircraft with booms on and off. Create maps and overlay on the treatment site maps; save for two years and file with the required application reports.

For more information, contact the Maine Board of Pesticides Control at 287-2731.



PAUL R. LEPAGE
GOVERNOR

STATE OF MAINE
DEPARTMENT OF AGRICULTURE, CONSERVATION AND FORESTRY
BOARD OF PESTICIDES CONTROL
28 STATE HOUSE STATION
AUGUSTA, MAINE 04333-0028

WALTER E. WHITCOMB
COMMISSIONER

HENRY S. JENNINGS
DIRECTOR

MEMORANDUM

Date: April, 2013
To: Board Members
From: Gary Fish
Subject: Policy regarding application of pesticides to unoccupied hotel rooms and apartments

Background

At the December 5, 2014 meeting the Board had a discussion regarding pesticide applications to hotel rooms and unoccupied apartments. State statutes define pesticide applications made to property open to use by the public as “custom applications” which may only be conducted by a licensed commercial applicator.

Section 2 (P) (2) of Chapter 10 defines “property open to use by public” and when those areas are NOT considered open to the public. One of those exemptions includes, “where the public has not been permitted upon the property at any time within seven days of when the property received a pesticide application.”

The Board recognized that indoor pesticide applications inherently pose greater risks to building occupants than outdoor applications because the confined space of a residential building inhibits both the dissipation and breakdown of airborne and surface pesticide residues. Due to these concerns, the Board came to a consensus that the term “property” means the entire building when it involves residential apartments and lodging places¹.

Board Policy

Based on the considerations described above, the Board adopted the following policy on April 24, 2015:

The Board determined that because indoor applications pose greater risks to building occupants, lodging places and apartment buildings should not be included as exemptions to areas open to the public. Therefore all pesticide applications to lodging places or apartment buildings must be made under the direct supervision of a licensed commercial applicator unless the public is excluded from the entire building for the full seven days.

¹Lodging Places - LODGING PLACES means every building or structure, or any part thereof, used, maintained, advertised or held out to the public as a place where sleeping accommodations are furnished to the public for business purposes. The term includes, but not by way of limitation, hotels, motels, guest homes and cottages. A Lodging License is required for any person or entity which rents out four or more rooms or cottages. CMR 10-144 Chapter 206

Excerpt from CMR 01-026, Chapter 10, Section 2 (P):

P. "Custom application" means an application of a pesticide:

1. Under contract or for which compensation is received;
 - a. For the purposes of this definition, "under contract" includes: verbal or written agreements to provide services which include the use of any pesticide; i.e., private or commercial rental agreements, pest control service agreements, landscape maintenance agreements, etc.
 - b. For purposes of this definition, compensation is deemed to have been received for a pesticide application where any form of remuneration has been or will be exchanged, including payment of cash, rent, or other financial consideration, or by the exchange of goods and/or services. This also includes any agreements where crops grown on rented land will be sold to the landowner or are otherwise grown for the benefit of the land owner.
2. To a property open to use by the public;
 - a. For purposes of this definition, property is deemed to be open to use by the public where its owner, lessee or other lawful occupant operates, maintains or holds the property open or allows access for routine use by members of the public. Persons are considered to be members of the public even though they may pay a fee or other compensation in order to make use of the property or may visit the property for a commercial purpose.
 - b. Property open to use by the public includes but is not limited to: shopping centers, office and store space routinely open to the public (i.e. rest rooms, self-service areas and display aisles), common areas of apartment buildings, occupied apartments, public pools and water parks, schools and other institutional buildings, public roads, organized recreational facilities, golf courses, campgrounds, parks, parking lots, ornamental and turf areas around condominiums, apartment buildings, stores malls and retail areas of greenhouses and nurseries if the public is allowed access before the pesticide restricted-entry or re-entry interval elapses.
 - c. Examples of property not open to use by the public include without limitation: farms, forest lands, and private residential or commercial property which is not routinely operated or maintained for use by the public or otherwise held open to public use.
 - d. Notwithstanding this definition, property shall not be deemed to be open for use by the public in the following cases:
 - i. where the property is devoted primarily to agricultural, forest, ornamental tree or plant production, but this exception shall not apply to campgrounds, leased inholdings or roads within such property which are open for use by the public;
 - ii. where the public has not been permitted upon the property at any time within seven days of when the property received a pesticide application;
 - iii. forestry rights of way where the property has been closed during the time of spraying or during the label restricted entry interval or re-entry period, whichever is greater.



PAUL R. LEPAGE
GOVERNOR

STATE OF MAINE
DEPARTMENT OF AGRICULTURE, CONSERVATION AND FORESTRY
BOARD OF PESTICIDES CONTROL
28 STATE HOUSE STATION
AUGUSTA, MAINE 04333-0028

WALTER E. WHITCOMB
COMMISSIONER

HENRY S. JENNINGS
DIRECTOR

MEMORANDUM

Date: April, 2013
To: Board Members
From: Gary Fish
Subject: Policy regarding application of pesticides to private lands open to use by the public

Background

At the December 5, 2014 meeting, the Board had a discussion regarding pesticide applications to private lands which are held open for public use. State statutes define pesticide applications made to property open to use by the public as “custom applications” which may only be conducted by a licensed commercial applicator.

Section 2 (P) (2) of Chapter 10 defines “property open to use by public.” Property is deemed to be open to use by the public where its owner, lessee or other lawful occupant operates, maintains or holds the property open or allows access for routine use by members of the public. The rule also defines when those areas are NOT considered open to the public.

One of those exemptions includes areas, “where the public has not been permitted upon the property at any time within seven days of when the property received a pesticide application.”

The Board discussed what the term “property” means in the context of this exemption and whether or not to interpret it in a way that allows land trusts and other land owners to control invasive plants or other vegetation and then close off only the area that was treated instead of the entire property.

Board Policy

Upon further consideration, on April 24, 2015, the Board determined that adoption of the following policy best serves the public interest:

Option 1: The Board determined that because pesticide applications to recreational areas, trails and parks pose a risk to sensitive populations, the exemption from consideration as an area open to the public is inappropriate. Therefore pesticide applications under those conditions will require supervision by a licensed commercial applicator unless the entire property is unoccupied for the entire seven days following the application of pesticides.

Option 2: The Board determined that because pesticide applications to recreational areas, trails and parks pose minimal risks, the exemption from consideration as an area open to the public is appropriate when the public is excluded from treated areas for seven days. Therefore pesticide applications under those circumstances will not require supervision by a licensed commercial applicator.

Proposed Administrative Consent Agreement Background Summary

Company: Dan Brown **License:** None

Origin of Case: Restricted use pesticide dealer inspection at Northeast Agricultural Sales in Detroit on 4-27-2012

Dates of Incident: April 13, 2010

Pesticide(s) Involved: Gramoxone Inteon Herbicide

Summary of Allegation(s): A Board inspector did a routine restricted use pesticide dealer inspection at Northeast Agricultural Sales in Detroit on April 27, 2012. As part of that inspection, the inspector asked for and received random, representative copies of Northeast Agricultural Sales sales transactions records for some 2010 restricted use pesticide sales. A review of those records revealed that Dan Brown purchased a 2 ½ gallon container of Gramoxone Inteon Herbicide on April 13, 2010. Gramoxone Inteon Herbicide is a restricted use pesticide that requires a pesticide applicator license to purchase. Brown was not licensed at the time of this purchase

Staff Action: A Board inspector collected a copy of Northeast Agricultural Sale's transaction record showing Brown's purchase of the restricted use pesticide. A consent agreement was given to Brown that included a \$50 penalty. Brown signed the consent agreement and paid the penalty.

Staff Findings: Brown purchased a restricted use pesticide without a pesticide applicator license.

Applicable Citations of Law: CMR 01-026 Chapter 40 Section 1(D) - Restricted use pesticides may be purchased and used only by applicators licensed by the Board as provided in Chapters 31 and 32.

Attachment(s):

- Consent agreement for Dan Brown

IN WITNESS WHEREOF, the parties have executed this Agreement of two pages.

DANIEL BROWN

By: _____ Date: _____

Type or Print Name: _____

BOARD OF PESTICIDES CONTROL

By: _____ Date: _____

Henry Jennings, Director

APPROVED:

By: _____ Date: _____

Mark Randlett, Assistant Attorney General

Proposed Administrative Consent Agreement Background Summary

Subject: Lucas Tree Experts Company
PO Box 958
Portland, Maine 04104-0958

Date of Incident(s): June 11, 2014

Background Narrative: On June 12, 2014, the Board received a complaint from a Scarborough resident who is a registry member on the 2014 Maine Pesticide Notification Registry (non-agricultural). The registry member stated she received no notification about a pesticide application that was made to a property listed as an abutter to her property on the 2014 pesticide notification registry. A follow-up inspection confirmed that a pesticide application was made without the required notification.

Summary of Violation(s): CMR 01-026 Chapter 28, Section 2 (D). Notification must be received between 6 hours and 14 days prior to the pesticide application.

Rationale for Settlement: The company entered into three previous consent agreements involving violations of the notification requirements for registry members. On July 23, 2010, a pesticide application was made and insufficient notification was given. On August 8, 2011, a pesticide application was made and the required notification was not provided. On June 13, 2013, a pesticide application was made and the required notification was not provided. Consequently, this violation is a subsequent violation pursuant to 7 M.R.S.A. § 616-A (2)(B) and these facts were taken into account when setting the penalty amount.

Attachments: Proposed Consent Agreement

**STATE OF MAINE
DEPARTMENT OF AGRICULTURE, CONSERVATION AND FORESTRY
BOARD OF PESTICIDES CONTROL**

In the Matter of:)	ADMINISTRATIVE CONSENT
Lucas Tree Experts Company)	AGREEMENT
PO Box 958)	AND
Portland, Maine 04104-0958)	FINDINGS OF FACT

This Agreement, by and between Lucas Tree Experts Company (hereinafter called the "Company") and the State of Maine Board of Pesticides Control (hereinafter called the "Board"), is entered into pursuant to 22 M.R.S. §1471 M (2)(D) and in accordance with the Enforcement Protocol amended by the Board on June 3, 1998.

The parties to this Agreement agree as follows:

1. That the Company provides lawn care services and has the firm license number SCF 15035 issued by the Board pursuant to 22 M.R.S. § 1471-D (1)(B).
2. That on June 11, 2014, Adam Bendiksen, a Company employee and a licensed commercial master applicator (CMA 46667), applied Merit 0.2 Plus Turf Fertilizer, Q4 Plus Turf Herbicide and Lesco Cross X Check Plus Multi-Insecticide to the lawn of customer Brian Young's residential property at 4 Cutlass Lane in Scarborough.
3. That the outdoor treated area at 4 Cutlass Lane is located within 250 feet from a property which is the residence of Laura Hannan at 17 Powderhorn Drive in Scarborough.
4. That Laura Hannan is listed on Maine's 2014 Pesticide Notification Registry, as described in CMR 01-026 Chapter 28, Section 2. Brian Young's residential property at 4 Cutlass Lane in Scarborough address is also listed on the Registry as a property within 250 feet of Laura Hannan's residence. The Registry is distributed to commercial applicators annually.
5. That commercial applicators are required by CMR 01-026 Chapter 28, Section 2 (D) to notify individuals listed on the Maine Pesticide Notification Registry at least six hours in advance of any pesticide application made within 250 feet of a registrant's listed property.
6. That the Company failed to comply with the notification requirements of CMR 01-026 Chapter 28, Section 2 (D). No notification was provided to Hannan prior to making the application described in paragraph two.
7. That the actions described in paragraphs two through six constitute a violation of CMR 01-026 Chapter 28, Section 2 (D).
8. That the Company entered into an Administrative Consent Agreement with the Board for insufficient notification to a person on the Maine Pesticide Notification Registry when a pesticide application was made on July 23, 2010. The Company entered into two other Administrative Consent Agreements with the Board for not providing notification to people on the Maine Pesticide Notification Registry when a pesticide applications were made on August 11, 2011 and June 3, 2013. Consequently, the violation described in paragraph seven is a subsequent violation pursuant to 7 M.R.S. § 616-A (2)(B).

9. That the Board has regulatory authority over the activities described herein.
10. That the Company expressly waives:
 - A. Notice of or opportunity for hearing;
 - B. Any and all further procedural steps before the Board; and
 - C. The making of any further findings of fact before the Board.
11. That this Agreement shall not become effective unless and until the Board accepts it.
12. That in consideration for the release by the Board of the cause of action which the Board has against the Company resulting from the violation referred to in paragraph seven, the Company agrees to pay a penalty to the State of Maine in the sum of \$2,000. (Please make checks payable to Treasurer, State of Maine). In addition, the Company will include a copy of their written policy with the signed consent agreement that outlines procedures in place to notify those individuals on the Maine Pesticide Notification Registry.

IN WITNESS WHEREOF, the parties have executed this Agreement of two pages.

LUCAS TREE EXPERTS COMPANY

By: _____ Date: _____

Type or Print Name: _____

BOARD OF PESTICIDES CONTROL

By: _____ Date: _____

Henry Jennings, Director

APPROVED:

By: _____ Date: _____

Mark Randlett, Assistant Attorney General

Proposed Administrative Consent Agreement Background Summary

Company: Shane Theriault
Theriault Lawn Care Inc.
212 Van Buren Road
Caribou, ME 04736

Licenses: Firm and applicator licenses not renewed prior to making commercial applications

Origin of Case: Board office staff noticed licenses for company and its employees had expired

Dates of Incidents: 2012, 2013 through July when licenses renewed, and 2014 through August when licenses renewed

Pesticide(s) Involved: Numerous lawn care, tree, mulch bed and curb/parking lot pesticides

Summary of Allegation(s): Commercial pesticide applications with an expired firm license and expired applicator licenses.

Staff Action: A Board inspector conducted an inspection with a company applicator on July 16, 2013. At that time, the applicator was applying a tank mix of two herbicides to the city of Presque Isle's curbs, guard rails and pavement crack and crevices. The inspector noted that one of the herbicides in the tank mix was labeled for agricultural crops, not for the site it was being applied to. At that time, the inspector also reviewed the applicator's pesticide log book.

On August 8, 2014, a Board inspector conducted a records/operations inspection with the company.

Staff Findings:

- Theriault Lawn Care company's firm license expired on 12-31-11.
- The company did not submit renewal paper work for the master applicator or firm licenses for 2012
- All licenses affiliated with the company were invalid as of 12-31-11
- The company made unlicensed pesticide applications in 2012
- All applications made in 2013 prior to license renewals in July of 2013 were unlicensed applications
- The company did not submit renewal paper work for the master applicator or firm licenses at the beginning of 2014
- Board received company firm and master applicator 2014 renewal paper work in August of 2014, Board renewed company licenses at that time
- All applications made in 2014 prior to license renewals in August were unlicensed applications
- Princep Caliber 90 herbicide labeling does not list curbs, guardrails and crack and crevices areas or any other non-crop areas as treatment sites.
- The company's application records were not complete. Size of the treated area and wind direction were not recorded.

Applicable Citations of Law:

- **22 M.R.S. § 1471-D**
 1. Certification required; commercial applicators and spray contracting firms. Certification is required for commercial applicators and spray contracting firms as follows.
 - A. No commercial applicator may use or supervise the use of any pesticide within the State without prior certification from the board, provided that a competent person who is not certified may use such a pesticide under the direct supervision of a certified applicator; and [1983, c. 819, Pt. A, §42 (NEW).]

B. No spray contracting firm may use or supervise the use of any pesticide within the State without prior certification from the board.

- **7 U.S.C. § 136j (a)(2)(G), 7 M.R.S.A. § 606 (2)(B) and 22 M.R.S.A § 1471-D(8)(F)**
Specifies that a pesticide may not be applied in a manner inconsistent with its labeling.
- **CMR 01-026 Chapter 50, Section 1(A)**
Specifies requirements for commercial application records, including size of area treated and wind direction.

**STATE OF MAINE
DEPARTMENT OF AGRICULTURE, CONSERVATION AND FORESTRY
BOARD OF PESTICIDES CONTROL**

Shane Theriault)	ADMINISTRATIVE CONSENT
Theriault Lawn Care Inc.)	AGREEMENT
212 Van Buren Road)	AND
Caribou, ME 04736)	FINDINGS OF FACT

This Agreement, by and between Theriault Lawn Care Inc. (hereinafter called the "Company") and the State of Maine Board of Pesticides Control (hereinafter called the "Board"), is entered into pursuant to 22 M.R.S. §1471-M (2)(D) and in accordance with the Enforcement Protocol amended by the Board on June 3, 1998.

The parties to this Agreement agree as follows:

1. That the Company operates a lawn care service in Caribou, Maine.
2. That the Company has had a spray contracting firm license as well as commercially licensed pesticide applicators dating back to 1987.
3. That Company was issued a firm license in 2009 that expired on December 31, 2011.
4. That the Company never submitted their license renewals for their 2012/2013 firm license or master applicator license. In addition, the Company never submitted their annual summary report for 2011, a requirement for license renewal.
5. That Board office staff called the Company at least two times as a reminder that they needed to renew their licenses and submit the necessary paperwork to do so. Staff also sent at least two sets of renewal paperwork. The Company did not respond.
6. That on July 16, 2013, a Board inspector conducted a pesticide inspection with Company employee/applicator John Belanger. Belanger was applying a tank mix of Lesco Prosecutor and Princep Caliber 90 herbicides to curbs, guardrails and crack and crevices to municipal property of the City of Presque Isle. The areas where these applications were occurring were areas open to the public.
7. That from the inspection described in paragraph six, the inspector determined that the Company was operating with no firm license, master applicator license or commercial operator licenses from 2012 through the date of the inspection. The company later renewed their firm license and applicator licenses on July 18, 2013.
8. That the use of any pesticide in an area open to use by the public constitutes a commercial pesticide application in accordance with 22 M.R.S. § 1471-C(5)B.
9. That 22 M.R.S. § 1471-D(1) establishes the certification required for commercial applicators and spray contracting firms. Certification is required for commercial applicators and spray contracting firms as follows: No commercial applicator may use or supervise the use of any pesticide within the State without prior certification from the board, provided that a competent person who is not certified may use such a pesticide under the direct supervision of a certified applicator, and no spray contracting firm may use or supervise the use of any pesticide within the State without prior certification from the board

10. That the conditions in paragraphs one through nine constitute multiple violations of 22 M.R.S. § 1471-D(1).
11. That a pesticide may not be applied in a manner inconsistent with its labeling as outlined in 7 U.S.C. § 136j (a)(2)(G), 7 M.R.S.A. § 606 (2)(B) and 22 M.R.S.A § 1471-D(8)(F).
12. That the Princep Caliber 90 herbicide labeling does not list curbs, guardrails and crack and crevices areas or any other non-crop areas as treatment sites.
13. That the circumstances described in paragraphs six, eleven, and twelve constitute a violation of 7 U.S.C. § 136j (a)(2)(G), 7 M.R.S.A. § 606 (2)(B) and 22 M.R.S.A § 1471-D(8)(F).
14. That, as a commercial applicator, pesticide application records must be kept as required by CMR 01-026 Chapter 50, Section 1(A).
15. That an inspection of the company's application records conducted during the inspection described in paragraph six, showed that the records were not complete. Size of the treated area and wind direction were not recorded.
16. That the circumstances described in paragraphs six, fourteen and fifteen constitute a violation of CMR 01-026 Chapter 50, Section 1(A).
17. That Board office staff sent the company a renewal packet for their 2014/2015 licenses. There was no response from the Company. On May 20, 2014, Board office staff sent the same license renewal packet to the Company as certified mail. The Company did not respond
18. On August 5, 2014, Board office staff sent the Company a letter stating that their commercial master applicator's license was not renewed, the Company's 2013 summary report was needed to renew their firm license and that because of this all commercial applicator licenses affiliated with the Company were terminated.
19. That on August 8, 2014, a Board inspector conducted a records/operations check with the Company.
20. That from the inspection in paragraph nineteen, it was determined that the Company made commercial pesticide applications and operated without a firm license, master applicator's license or commercial operator applicator licenses from the beginning of 2014 to the date of the inspection in paragraph nineteen.
21. That on August 29, 2014, the Board received the license renewal paperwork for the Company's firm license and master applicator's license. At that time those licenses were renewed and the suspended commercial operator applicator licenses affiliated with the Company were reinstated.
22. That the circumstances described in paragraphs eight, nine and nineteen through twenty-one, constitute violations of 22 M.R.S. § 1471-D(1) from the beginning of the 2014 season through August 29, 2014.
23. That a review of the Company's pesticide applicator records during the inspection in paragraph nineteen, determined that the records were incomplete. The size of the area treated and wind direction were not kept.
24. That the circumstances described in paragraphs fourteen, nineteen and twenty-three constitute a violation of CMR 01-026 Chapter 50, Section 1(A).
25. That the Board has regulatory authority over the activities described herein.

26. That the Company expressly waives:
 - a. Notice of or opportunity for hearing;
 - b. Any and all further procedural steps before the Board; and
 - c. The making of any further findings of fact before the Board.
27. That this Agreement shall not become effective unless and until the Board accepts it.
28. That the Board has regulatory authority over the activities described herein.
29. That the Company expressly waives:
 - d. Notice of or opportunity for hearing;
 - e. Any and all further procedural steps before the Board; and
 - f. The making of any further findings of fact before the Board.
30. That this Agreement shall not become effective unless and until the Board accepts it.
31. That, in consideration for the release by the Board of the causes of action which the Board has against the Company resulting from the violations referred to in paragraphs ten, thirteen, sixteen, twenty-two and twenty-four, the Company agrees to pay to the State of Maine the sum of \$500. (Please make checks payable to Treasurer, State of Maine).

IN WITNESS WHEREOF, the parties have executed this Agreement of three pages.

THERIAULT LAWN CARE INC.

By: _____ Date: _____

Type or Print Name: _____

BOARD OF PESTICIDES CONTROL

By: _____ Date: _____

Henry Jennings, Director

APPROVED

By: _____ Date: _____

Mark Randlett, Assistant Attorney General



127th MAINE LEGISLATURE

FIRST REGULAR SESSION-2015

Legislative Document

No. 708

H.P. 484

House of Representatives, March 5, 2015

An Act To Limit the Use of Pesticides on School Grounds

Reference to the Committee on Agriculture, Conservation and Forestry suggested and ordered printed.

A handwritten signature in cursive script that reads "R B. Hunt".

ROBERT B. HUNT
Clerk

Presented by Representative DAUGHTRY of Brunswick.
Cosponsored by Senator MILLETT of Cumberland and
Representatives: BROOKS of Lewiston, DEVIN of Newcastle, FECTEAU of Biddeford,
HICKMAN of Winthrop, HUBBELL of Bar Harbor, MONAGHAN of Cape Elizabeth,
WELSH of Rockport, Senator: GERZOFSKY of Cumberland.

1 **Be it enacted by the People of the State of Maine as follows:**

2 **Sec. 1. 20-A MRSA §6306** is enacted to read:

3 **§6306. Use of pesticides in schools and on school grounds**

4 **1. Definitions.** As used in this section, unless the context otherwise indicates, the
5 following terms have the following meanings.

6 A. "Lawn care pesticide" means a pesticide registered by the United States
7 Environmental Protection Agency and labeled pursuant to the Federal Insecticide,
8 Fungicide and Rodenticide Act, 7 United States Code, Section 135 et seq. for use on
9 lawn, garden and ornamental sites or areas.

10 B. "Pesticide" has the same meaning as in 7 United States Code, Section 136(u).

11 C. "School" means a public elementary school, secondary school or kindergarten, or
12 a nursery school that is part of a public elementary or secondary school, or a private
13 elementary school, secondary school or kindergarten, or a nursery school that is part
14 of a private elementary school or secondary school, approved under section 2901.

15 D. "School grounds" means land associated with a school building, including
16 playgrounds, athletic fields, lawns, agricultural and recreational fields, walkways,
17 fence lines and any other outdoor area used by students or staff, including property
18 owned by a municipality or private entity that is regularly used for school activities.

19 **2. Pesticides applications in school buildings.** The application of pesticides in
20 school buildings must comply with Title 7, chapter 103, subchapter 2-A, Title 22, chapter
21 258-A and rules adopted by the Department of Agriculture, Conservation and Forestry,
22 Board of Pesticides Control under those chapters.

23 **3. Allowed uses of pesticides on school grounds.** Pesticides, including lawn care
24 pesticides, may be used on school grounds only:

25 A. To control, repel or eliminate stinging or biting insects when there is an urgent
26 threat to the health or safety of a student or staff member;

27 B. In response to the presence of animals or insects, including mosquitoes and ticks,
28 identified as a public health nuisance by the Department of Health and Human
29 Services, Maine Center for Disease Control and Prevention or a local public health
30 officer; or

31 C. On an agricultural field in accordance with the manufacturer's instructions for use
32 of the pesticides for appropriate pest management.

33 **Sec. 2. Adoption of rules minimizing or avoiding pesticides use on school**
34 **grounds.** No later than January 1, 2016, the Commissioner of Education shall adopt
35 rules to implement landscaping design that minimizes or avoids the necessity of the use
36 of pesticides on school grounds for new construction of school facilities.

1
2
3
4
5
6
7
8

SUMMARY

This bill restricts the use of pesticides on school grounds. It allows their use only in situations that pose a health threat to a student or staff member, in response to the presence of animals or insects identified as a public health nuisance or on agricultural fields in accordance with the manufacturer's instructions. It requires the Commissioner of Education to adopt rules to implement landscaping design that minimizes or avoids the necessity of the use of pesticides on school grounds for new construction of school facilities.



127th MAINE LEGISLATURE

FIRST REGULAR SESSION-2015

Legislative Document

No. 817

S.P. 291

In Senate, March 10, 2015

An Act Regarding Aerial Pesticide Spray Projects

Submitted by the Department of Agriculture, Conservation and Forestry pursuant to Joint Rule 204.

Reference to the Committee on Agriculture, Conservation and Forestry suggested and ordered printed.

A handwritten signature in cursive script that reads "Heather J.R. Priest".

HEATHER J.R. PRIEST
Secretary of the Senate

Presented by Senator SAVIELLO of Franklin.
Cosponsored by Representative NOON of Sanford and
Senator: DILL of Penobscot, Representatives: BLACK of Wilton, EDGECOMB of Fort
Fairfield.

1 **Be it enacted by the People of the State of Maine as follows:**

2 **Sec. 1. 22 MRSA §1444, sub-§2**, as enacted by PL 1997, c. 215, §1, is amended
3 to read:

4 **2. Aerial spraying.** When the infestation causing a public health nuisance may be
5 controlled by the aerial spraying of pesticides, the municipal officers in the affected
6 municipality may conduct aerial spraying subject to rules adopted by the Board of
7 Pesticides Control, pursuant to Title 7, section 610 and Title 22, section 1471-R,
8 ~~subsection 3, paragraph C 1471-M~~, except that:

9 A. The municipality ~~rather than the applicator~~ is responsible for compliance with the
10 notification and consent regulations;

11 B. Landowners who are sent written notification by mail, sent to the landowner's last
12 known address as contained in the municipal assessing records and who fail to
13 respond to the notice within 30 days are deemed to have consented to aerial spraying;

14 C. A landowner's written consent to spray remains valid unless the municipal
15 officers are notified in writing at least 90 days before spraying is to occur that:

16 (1) The landowner withdraws consent; or

17 (2) Ownership of the property has been transferred and the notice contains the
18 name and mailing address of the new owner;

19 ~~D. Any such notice sent or consent received in calendar year 1997 prior to the~~
20 ~~effective date of this chapter constitutes adequate notice or consent under the law;~~

21 E. Written notice to the landowners must identify the chemicals to be used in the
22 aerial spraying; and

23 F. Public notice of the date of the aerial spraying, subject to change because of
24 weather conditions, must be given 24 hours prior to the spraying.

25 **Sec. 2. 22 MRSA §1471-C, sub-§5**, as amended by PL 2007, c. 245, §1, is
26 further amended to read:

27 **5. Commercial applicator.** "Commercial applicator" means any person, ~~except a~~
28 ~~government pesticide supervisor~~, whether or not the person is a private applicator with
29 respect to some uses, who uses or supervises the use of any limited or restricted-use
30 pesticides on any property other than as provided by subsection 22, or who uses general-
31 use pesticides in custom application on such property. "Commercial applicator" also
32 includes individuals who apply any pesticides in connection with their duties as officials
33 or employees of federal, state or local governments.

34 **Sec. 3. 22 MRSA §1471-C, sub-§11-A**, as enacted by PL 1981, c. 374, §2, is
35 repealed.

36 **Sec. 4. 22 MRSA §1471-C, sub-§§16-C, 23-A and 23-C**, as enacted by PL
37 1983, c. 819, Pt. A, §41, are repealed.

1 **Sec. 5. 22 MRSA §1471-D, sub-§2-A**, as enacted by PL 1981, c. 374, §3, is
2 repealed.

3 **Sec. 6. 22 MRSA §1471-D, sub-§2-B**, as enacted by PL 1983, c. 819, Pt. A, §43,
4 is repealed.

5 **Sec. 7. 22 MRSA §1471-D, sub-§5**, as amended by PL 1983, c. 819, Pt. A, §45,
6 is further amended to read:

7 **5. Issuance.** ~~No~~ A license or certification may not be issued by the board, unless the
8 board determines that the standards for licensing and certification have been met as to
9 those categories for which the applicant has applied and qualified. ~~In the case of the~~
10 ~~spotter and monitor, the board shall set minimal proficiency requirements with the~~
11 ~~understanding that the board may choose to change these standards from time to time.~~
12 ~~The enforcement personnel of the Board of Pesticides Control shall be certified to meet at~~
13 ~~least the minimal proficiency requirements required of spotters and monitors.~~ If a license
14 or certification is not issued as applied for, the board shall provide written notice to the
15 applicant of the reasons therefor. The license or certificate may be issued upon such
16 terms and conditions as the board ~~deems~~ considers necessary for the protection of the
17 public health, safety and welfare, and for enforcement and administration of this chapter
18 and the rules ~~promulgated~~ adopted pursuant to this chapter.

19 **Sec. 8. 22 MRSA §1471-D, sub-§6**, as amended by PL 1997, c. 454, §8, is
20 further amended to read:

21 **6. Renewal.** Licenses for commercial applicators, ~~government pesticide supervisors,~~
22 ~~spotters, monitors,~~ spray contracting firms, pesticide dealers and private applicators are
23 valid for such period as prescribed by the board by rule. Application for renewal must be
24 accompanied by such reasonable fee as the board may by rule require. The board may, by
25 rule, require that such renewal application include reexamination or other procedures
26 designed to assure a continuing level of competence to distribute, use or supervise the use
27 of pesticides safely and properly.

28 If the board fails to renew a license upon application of the licensee or certificate holder,
29 it shall afford the licensee or certificate holder an opportunity for a hearing in conformity
30 with Title 5, chapter 375, subchapter ~~IV~~ 4.

31 **Sec. 9. 22 MRSA §1471-M, sub-§1, ¶A**, as amended by PL 1981, c. 374, §8, is
32 further amended to read:

33 A. Establish categories, and where applicable subcategories, of commercial pesticide
34 applicators ~~and government pesticide supervisors~~ depending upon the nature and
35 extent of the pesticide use, the type of pesticide equipment, the degree of knowledge
36 or skill required in their application and such other factors as the board ~~deems~~
37 considers relevant, ~~provided that as long as~~ such categories ~~shall be~~ are consistent
38 with, but not limited to, the categories established by the United States
39 Environmental Protection Agency;

40 **Sec. 10. 22 MRSA §1471-M, sub-§1, ¶E**, as amended by PL 1983, c. 819, Pt. A,
41 §52, is further amended to read:

1 E. Establish guidelines and requirements for reporting of information by commercial
2 applicators, pesticide dealers, and spray contracting firms ~~and monitors~~ to the board;
3 and

4 **Sec. 11. 22 MRSA §1471-M, sub-§1, ¶F**, as enacted by PL 1981, c. 374, §9, is
5 repealed.

6 **Sec. 12. 22 MRSA §1471-M, sub-§1, ¶G**, as enacted by PL 1983, c. 819, Pt. A,
7 §53, is repealed.

8 **Sec. 13. 22 MRSA §1471-R**, as enacted by PL 1983, c. 819, Pt. A, §54 and
9 amended by PL 2011, c. 657, Pt. W, §7 and PL 2013, c. 405, Pt. A, §23, is repealed.

10 **Sec. 14. 22 MRSA §§1471-S and 1471-T**, as enacted by PL 1983, c. 819, Pt. A,
11 §54, are repealed.

12 **SUMMARY**

13 This bill repeals notification and reporting provisions for forest insect aerial pesticide
14 spray projects. It eliminates provisions related to government pesticide supervisors,
15 spotters and monitors, including the certification, licensing and associated reporting
16 requirements. Other provisions governing notification and reporting requirements for
17 outdoor pesticide applications are contained in the Department of Agriculture,
18 Conservation and Forestry, Board of Pesticides Control rules.



127th MAINE LEGISLATURE

FIRST REGULAR SESSION-2015

Legislative Document

No. 1098

H.P. 758

House of Representatives, March 25, 2015

An Act To Protect Children from Exposure to Pesticides

Reference to the Committee on Agriculture, Conservation and Forestry suggested and ordered printed.

A handwritten signature in cursive script that reads "R B. Hunt".

ROBERT B. HUNT
Clerk

Presented by Representative CHIPMAN of Portland.
Cosponsored by Representatives: BLACK of Wilton, CHAPMAN of Brooksville, DUNPHY of Old Town, HICKMAN of Winthrop, MAREAN of Hollis, McELWEE of Caribou, NOON of Sanford, Senator: SAVIELLO of Franklin.



127th MAINE LEGISLATURE

FIRST REGULAR SESSION-2015

Legislative Document

No. 1099

H.P. 759

House of Representatives, March 25, 2015

**An Act To Establish a Fund for the Operations and Outreach
Activities of the University of Maine Cooperative Extension Animal
and Plant Disease and Insect Control Laboratory**

Reference to the Committee on Agriculture, Conservation and Forestry suggested and ordered printed.

A handwritten signature in cursive script that reads "R B. Hunt".

ROBERT B. HUNT
Clerk

Presented by Representative BLACK of Wilton.
Cosponsored by Senator SAVIELLO of Franklin and
Representatives: DUCHESNE of Hudson, HANLEY of Pittston, LUCHINI of Ellsworth,
MAREAN of Hollis, SKOLFIELD of Weld, Senators: ALFOND of Cumberland, CUSHING
of Penobscot.

1 **Be it enacted by the People of the State of Maine as follows:**

2 **Sec. 1. 7 MRSA c. 417** is enacted to read:

3 **CHAPTER 417**

4 **ANIMAL AND PLANT DISEASE AND INSECT CONTROL FUND**

5 **§2431. Fund established**

6 The Animal and Plant Disease and Insect Control Fund, referred to in this chapter as
7 "the fund," is established. The fund is administered by the University of Maine
8 Cooperative Extension and consists of funds received from Title 36, chapter 723, any
9 appropriation or allocation from the Legislature and contributions from private and public
10 sources. The fund, to be accounted within the University of Maine Cooperative
11 Extension, must be held separate and apart from all other money, funds and accounts.
12 Eligible investment earnings credited to the assets of the fund become part of the assets of
13 the fund. Any balance remaining in the fund at the end of a fiscal year must be disbursed
14 to the University of Maine Cooperative Extension.

15 **§2432. Expenditures from fund; distribution**

16 Funds in the fund, after reimbursement for fund administration costs, must be
17 distributed by the University of Maine Cooperative Extension as follows:

18 **1. Pesticide container fee reimbursement.** Reimbursement annually to Maine
19 Revenue Services to pay for administrative costs from collection of the pesticide
20 container fee under Title 36, section 4911, subsection 3;

21 **2. Board of Pesticides Control reimbursement.** Reimbursement annually to the
22 Board of Pesticides Control, established in Title 5, section 12004-D, subsection 3, to pay
23 for costs under Title 36, section 4911, subsection 5;

24 **3. Pest management education.** To the University of Maine Cooperative Extension
25 for outreach and education initiatives on pest management and pesticide safety, including
26 community integrated pest management and medical and veterinary pest management,
27 focusing on health-related issues caused by ticks and mosquitoes, and pesticide
28 application and use, focusing on pollinator health and safety; and

29 **4. Laboratory operations.** To the University of Maine Cooperative Extension for
30 costs of its animal and plant disease and insect control laboratory, including testing ticks
31 provided by the public for pathogenic organisms and general laboratory operations
32 involving pesticide management and insect control.

33 **Sec. 2. 36 MRSA c. 723** is enacted to read:

34 **CHAPTER 723**

35 **PESTICIDE CONTAINER FEE**



127th MAINE LEGISLATURE

FIRST REGULAR SESSION-2015

Legislative Document

No. 1105

H.P. 766

House of Representatives, March 26, 2015

An Act To Protect Populations of Bees and Other Pollinators

Reference to the Committee on Agriculture, Conservation and Forestry suggested and ordered printed.

A handwritten signature in cursive script that reads "R B. Hunt".

ROBERT B. HUNT
Clerk

Presented by Representative McCABE of Skowhegan.
Cosponsored by Representatives: HARLOW of Portland, HICKMAN of Winthrop, SAUCIER of Presque Isle.

1 **Be it enacted by the People of the State of Maine as follows:**

2 **Sec. 1. 7 MRSA c. 417** is enacted to read:

3 **CHAPTER 417**

4 **LABELING AND ADVERTISING OF PLANTS**

5 **§2441. Pollinator protection**

6 **1. Definition.** As used in this section, "insecticide lethal to pollinators" means a
7 product that has a detectable level of systemic insecticide that:

8 A. Has a pollinator protection box on the label; or

9 B. Has a precautionary statement concerning pollinators, bees or honeybees in the
10 environmental hazards section of the insecticide product label.

11 "Insecticide lethal to pollinators" includes, but is not limited to, the neonicotinoid class of
12 insecticides that affect the central nervous system of pollinators and may cause pollinator
13 paralysis or death.

14 **2. Prohibition.** A person may not label or advertise an annual plant, bedding plant
15 or other plant, plant material or nursery stock as beneficial to pollinators if the annual
16 plant, bedding plant or other plant, plant material or nursery stock has been treated with
17 an insecticide lethal to pollinators.

18 **SUMMARY**

19 This bill prohibits labeling or advertising an annual plant, bedding plant or other
20 plant, plant material or nursery stock as beneficial to pollinators if the plant or material
21 has been treated with an insecticide absorbed by a plant that makes the plant lethal to
22 pollinators.



127th MAINE LEGISLATURE

FIRST REGULAR SESSION-2015

Legislative Document

No. 1106

H.P. 767

House of Representatives, March 26, 2015

An Act To Compensate Beekeepers for Hive Losses

Reference to the Committee on Agriculture, Conservation and Forestry suggested and ordered printed.

A handwritten signature in cursive script that reads "Robert B. Hunt".

ROBERT B. HUNT
Clerk

Presented by Representative McCABE of Skowhegan.

Cosponsored by Representatives: DUNPHY of Old Town, HARLOW of Portland, HICKMAN of Winthrop, McELWEE of Caribou.

1 **Be it enacted by the People of the State of Maine as follows:**

2 **Sec. 1. 7 MRSA Pt. 6-A, c. 519** is enacted to read:

3 **CHAPTER 519**

4 **DEFINITIONS**

5 **§2691. Definitions**

6 As used in this Part, unless the context otherwise indicates, the following terms have
7 the following meanings.

8 **1. Apiary.** "Apiary" means a place where a collection of one or more hives or
9 colonies of honeybees or the nuclei of honeybees are kept.

10 **2. Colony.** "Colony" means the aggregate of worker honeybees, drones, the queen,
11 and developing young honeybees living in a hive or other dwelling.

12 **3. Hive.** "Hive" means a frame hive, box hive, box, barrel, log gum, skep or any
13 other receptacle or container, natural or artificial, or any part of one, that is used to house
14 honeybees.

15 **4. Honeybee.** "Honeybee" means any stage of the common honeybee, *Apis*
16 *mellifera*.

17 **5. Honeybee owner.** "Honeybee owner" means a person who owns an apiary.

18 **Sec. 2. 7 MRSA §2871**, as enacted by PL 1985, c. 572, is amended to read:

19 **§2871. Rules**

20 The commissioner shall adopt rules to implement and enforce this Part in accordance
21 with the Maine Administrative Procedure Act, ~~Title 5, chapter 375~~. Rules adopted under
22 this section are routine technical rules as defined in Title 5, chapter 375, subchapter 2-A.

23 **Sec. 3. 7 MRSA c. 533** is enacted to read:

24 **CHAPTER 533**

25 **COMPENSATION FOR HONEYBEES KILLED BY PESTICIDES**

26 **§2891. Compensation for honeybees killed by pesticides**

27 A person may be compensated for an acute pesticide poisoning resulting in the death
28 of honeybees or loss of honeybee colonies owned by the person in accordance with this
29 section.

30 **1. Compensation.** If the department determines that honeybee death or loss of a
31 honeybee colony was caused by an acute pesticide poisoning and the pesticide applicator:

1 identified or the pesticide applicator applied the pesticide product in a manner consistent
2 with the pesticide product's label, the Department of Agriculture, Conservation and
3 Forestry may compensate the honeybee owner for the fair market value of the honeybees
4 or honeybee colony. If the pesticide applicator can be identified and the applicator
5 applied the pesticide product in a manner inconsistent with the product's label, the
6 department may collect a penalty from the pesticide applicator sufficient to compensate
7 the honeybee owner for the fair market value of the honeybees or honeybee colony and
8 shall award the money to the honeybee owner. The bill provides that fair market value is
9 determined by the department upon recommendation by academic experts and honeybee
10 owners.

**INTERIM REPORT ON THE ENVIRONMENTAL RISK
ADVISORY COMMITTEE STUDY OF PESTICIDES AND
LOBSTERS**

**From
The Maine Board of Pesticides Control**

**To
The Joint Standing Committee on
Agriculture, Conservation and Forestry
127th Maine State Legislature**

January, 2015

TABLE OF CONTENTS

SECTION I: INTRODUCTION	1
SECTION II: BACKGROUND	1
SECTION III: ENVIRONMENTAL RISK ADVISORY COMMITTEE AND LITERATURE REVIEWS	2
SECTION IV: 2014 MARINE SEDIMENT SAMPLING PROJECT	2
SECTION V: NEXT STEPS	3

APPENDICES

**APPENDIX I: LETTER FROM THE 126TH LEGISLATURE COMMITTEE ON
AGRICULTURE, CONSERVATION AND FORESTRY**

APPENDIX II: ENVIRONMENTAL RISK ADVISORY COMMITTEE MEMBERS

APPENDIX III: 2014 MARINE SEDIMENT SAMPLING RESULTS

INTERIM REPORT ON THE ENVIRONMENTAL RISK ADVISORY COMMITTEE STUDY OF PESTICIDES AND LOBSTERS

SECTION I: INTRODUCTION

In February 2014, the Maine Board of Pesticides Control (BPC) acknowledged there were multiple indicators suggesting that a careful and methodical analysis of the potential threats of pesticide use to Maine's lobster fishery would be both timely and appropriate. Consequently, the BPC voted to convene an Environmental Risk Advisory Committee (ERAC) to "examine whether current pesticide residues have the potential to affect the lobster industry in Maine directly or via impact on other marine organisms." Maine's Joint Standing Committee on Agriculture, Conservation and Forestry, in a letter to the BPC, supported the formation and purpose of the ERAC and requested reports in January 2015 and January 2017. This report is in response to the Committee's request.

SECTION II: BACKGROUND

The BPC has regulatory oversight responsibility covering the use and distribution of pesticides in the State of Maine. As part of its responsibilities, the BPC monitors emerging scientific research on pesticides and their potential effects. One area of recent research that the BPC staff has been tracking is the presence, accumulation and potential impacts of synthetic pyrethroid insecticides in aquatic sediments.

Based on research conducted in other states, the BPC determined there would be value in conducting in-state sediment sampling as one way of evaluating the applicability of national research. Consequently, over a three-year period, between 2008 and 2010, the BPC staff collected sediment samples from a small number of streambeds in the greater Portland area. The samples were analyzed at the University of Maine for common synthetic pyrethroid insecticides. The project provided evidence that this class of insecticides was likely present in Maine's aquatic sediments.

In January of 2014, a bill was introduced into the Maine Legislature that sought to prohibit the use of two insecticides commonly used for mosquito control in many states: methoprene and resmethrin. LD 1678 was based on a similar bill from Connecticut that was intended to protect the local lobster fishery from potential adverse effects. The BPC and the Maine Department of Agriculture, Conservation and Forestry both opposed LD 1678 for a variety of reasons:

- The Connecticut bill was based on research that is no longer considered valid.
- There is currently no compelling evidence that these two insecticides pose unreasonable threats to Maine's lobster fishery.
- At this time, use of both methoprene and resmethrin in Maine is largely limited to relatively small amounts in flea and tick control products for pets.
- Unlike many states where governmental mosquito control programs are well established, Maine does not currently use, nor has it historically used, either insecticide targeted by LD 1678 for mosquito control. However, given that mosquito-borne diseases are on the rise in Maine, it would be prudent to keep control options available should a mosquito-borne disease emergency arise.

- Methoprene fills a potential niche for controlling mosquito larvae in circumstances in which the preferred biological larvicides are ineffective. Any use of methoprene in Maine could be carefully managed to minimize any risks to the marine environment.
- Methoprene has a low mammalian toxicity, degrades rapidly in sunlight, is metabolized rapidly in soil, and does not leach.
- Banning products without a careful assessment of what is likely to replace them often results in substitution with higher risk products.
- There are other insecticides that are commonly used in Maine which are more likely to be present in the marine environment where juvenile lobsters are present.
- The public interest would be better served by a systematic assessment of whether pesticides may pose a threat to Maine's lobster fishery.

Maine's Joint Standing Committee on Agriculture, Conservation and Forestry held a public hearing and work session on LD 1678 and voted the bill out of committee as ought-not-to-pass. The Committee agreed that there was insufficient scientific basis for banning two mosquito insecticides not currently used in Maine and preferred the recommended path of assessing the broader question about whether pesticides—in general—present a risk to the fishery. Consequently, the Committee chairs wrote to the BPC agreeing with the formation of an ERAC and asking the BPC to report on its progress in January of 2015 and 2017.

SECTION III: ENVIRONMENTAL RISK ADVISORY COMMITTEE AND LITERATURE REVIEWS

The BPC has convened an ERAC on multiple occasions over the last 25 years to evaluate environmental concerns specific to Maine. ERAC membership varies according to the issue at hand, with in-state expertise selected based on the nature of the particular concern. The most recent ERAC looked at the risks associated with browntail moth spraying along the Maine coast and also focused on the potential impacts to the lobster fishery.

At its February 21, 2014 meeting, the Board approved the formation of an ERAC composed of scientists from the Department of Marine Resources, the Department of Environmental Protection, the University of Maine system, and is assisted by the BPC staff. The ERAC met on April 18, 2014 and agreed on a plan to collect marine sediments from the edge of the intertidal zone and submit those samples for analysis.

At the same time, the BPC staff embarked on a process to review all of the pesticide active ingredients used in the state to determine which are the top priorities in relation to lobsters. First, use patterns were researched to determine which active ingredients might have the potential to reach marine sediments and thereby expose developing lobsters to pesticide residues. This review generated a list of approximately 725 pesticide active ingredients, which were then grouped based on modes of action and their toxic effects on the biological pathways found in aquatic and sediment dwelling species. Using an environmental fate assessment based on EPA data, the list was further refined to only those active ingredients likely to be found in sediment. Active ingredients given further consideration were those with both a high toxicity to aquatic and sediment dwelling species and a likelihood to persist in sediment. The staff then worked with certified laboratories to determine which of those active ingredients could be identified using existing screening methods. This assessment produced the

following list of priority compounds for analysis: pyrethrins, synthetic pyrethroids (including resmethrin), methoprene and fipronil. If other compounds of concern are identified, they will be evaluated at a later time.

The BPC is currently working with a non-profit contractor as well as the Muskie School of Public Health at the University of Maine System to conduct literature reviews for all active ingredients of concern. The literature reviews will provide the most current and scientifically defensible information available to better evaluate potential risks from pesticide use to Maine's lobster fishery.

SECTION IV: 2014 MARINE SEDIMENT SAMPLING PROJECT

The BPC ERAC recommended that the BPC staff, in consultation with the Department of Marine Resources, collect marine sediment samples near the outer edge of the intertidal zone and submit those samples for pesticide analysis. The BPC then sought laboratories with the appropriate expertise.

Pesticide residue analysis—especially in sediments—is a complicated and expensive proposition because:

- There are nearly 1,000 different pesticide active ingredients;
- Most pesticide active ingredients are large, complex organic molecules;
- Sediments are also composed—in part—of large, complex organic molecules; and
- There is not a lot of demand for pesticide residue analysis.

As a result, there are very few qualified laboratories. Two laboratories were selected for this work based on their experience, analyte coverage and method sensitivity: the Montana State Analytical Laboratory and the Southwest Research Institute.

The BPC calculated that the budget allowed for 20 sediment sampling sites. Sites were selected based on:

- Proximity to inlets that drain developed and agricultural areas near the coast;
- The presence of fine-grained sediments; and
- Distribution covering all the major watersheds.

Sediment sampling was delayed in 2014 due to complications identifying competent laboratories and getting contracts approved. Samples were collected between August 27 and September 10, 2014 and shipped to the two contract laboratories.

The Montana Analytical Laboratory, which ran the more sensitive analysis for pyrethroids, detected bifenthrin (a synthetic pyrethroid) at 11 of the 20 sample sites and cypermethrin (another synthetic pyrethroid) at one site. Southwest Research Institute reported no detections. Neither methoprene nor resmethrin—the targets of LD 1678—were detected. Complete results are shown in Appendix III. These data are preliminary and are not appropriate for a risk assessment process pending verification and correction for organic carbon content of the sediment.

The focus of the ongoing literature review is to assess whether the presence of bifenthrin and/or cypermethrin in intertidal marine sediments at the reported levels poses a risk to the lobster. However,

nothing in the Environmental Protection Agency's current pesticide registration documents suggests that an unreasonable risk to aquatic invertebrates exists.

SECTION V: NEXT STEPS

During 2015—to the extent that resources allow—the BPC plans to continue its assessment of the potential impacts of pesticides on the lobster resource as follows:

- The ERAC will reconvene to evaluate the 2014 methods and and make recommendations for 2015.
- Sediment sampling will likely be repeated with possible improvements/adjustments based on lessons learned from the 2014 sampling and recommendations made by the ERAC.
- Storm water samples will be collected from the same approximate locations as the sediment samples and analyzed at the Montana Analytical Laboratory using their Universal Water Screen which tests for at least 96 commonly applied pesticides.
- The scientific literature review will continue, with priority given to compounds detected in the sampling program. Bifenthrin and cypermethrin will now become the highest priority compounds for review. The purpose of the literature review is to evaluate whether compounds detected pose a potential threat to the lobster fishery.
- Additional sampling may occur based on available funds and recommendations made by the ERAC.

When results are available from the 2015 sampling and literature review activities, the ERAC will meet again and determine whether additional inquiry is warranted. ERAC findings and any potential recommendations will be presented to the full BPC for consideration. The BPC will then determine whether any remedial actions are appropriate. A follow-up report detailing the BPC findings will be submitted to the Joint Standing Committee on Agriculture, Conservation and Forestry in January of 2017.

APPENDIX I

SENATE

ELOISE A. VITELLI, District 19, Chair
JAMES A. BOYLE, District 6
ROGER L. SHERMAN, District 34



KAREN NADEAU-DRILLEN, Legislative Analyst
NATASHA IRVING, Committee Clerk

HOUSE

JAMES F. DILL, Old Town, Chair
PETER S. KENT, Woolwich
CRAIG V. HICKMAN, Winthrop
BRIAN L. JONES, Freedom
WILLIAM F. NOON, Sanford
ROBERT J. SAUCIER, Presque Isle
DEAN A. CRAY, Palmyra
DONALD G. MAREAN, Hollis
RUSSELL J. BLACK, Wilton
JEFFREY L. TIMBERLAKE, Turner

State of Maine
ONE HUNDRED AND TWENTY-SIXTH LEGISLATURE
COMMITTEE ON AGRICULTURE, CONSERVATION AND FORESTRY

March 18, 2014

Henry Jennings, Director, Board of Pesticides Control
Department of Agriculture, Conservation and Forestry
28 State House Station
Augusta, ME 04333-0028

Dear Mr. Jennings,

Earlier this session, the Joint Standing Committee on Agriculture, Conservation and Forestry (ACF) voted unanimously "ought not to pass" on the above referenced bill. LD 1678 proposed to prohibit the use of methoprene and resmethrin, two chemicals used for mosquito control, in any body of water that drains into the Gulf of Maine or on land from which runoff could enter into any such waterway. While the ACF Committee did not agree with the proposed course of this legislation, we commend the sponsor for bringing this issue forward.

In written testimony, the sponsor of LD 1678, Representative Kumiega, expressed concern about the negative impact methoprene and resmethrin may have on lobster populations. According to the University of Maine's Lobster Institute, Maine is the nation's largest lobster producer – bringing in over three-quarters of the nation's catch. The total impact of Maine's lobster industry on the state economy is approximately \$1.7 billion.

It is our understanding that the Board of Pesticides Control (BPC) has volunteered to convene an Environmental Risk Advisory Committee (ERAC) to look at all pesticides and assess potential adverse impacts of pesticide use on the state's lobster resource. We also understand that BPC, in collaboration with the Department of Marine Resources (DMR), will begin identifying high priority areas for sampling to identify which pesticides are most prevalent in the marine environment.

We respectfully request that BPC provide the ACF Committee an interim report by January 2015 and a final report by January 2017 on the work of the ERAC and on the results of BPC and DMR sampling efforts. Thank you for your efforts on this important issue.

Sincerely,

Handwritten signature of Eloise A. Vitelli.

Sen. Eloise A. Vitelli, Senate Chair

Handwritten signature of James F. Dill.

Rep. James F. Dill, House Chair

Cc: Members, Joint Standing Committee on Agriculture, Conservation and Forestry
Members, Joint Standing Committee on Marine Resources
Hon. Walter Whitcomb, Commissioner, DACF
Patrick C. Keliher, Commissioner, DMR
Representative Walter Kumiega

APPENDIX II: ENVIRONMENTAL RISK ADVISORY COMMITTEE MEMBERS

Chair

Curtis C. Bohlen, Ph.D

Board of Pesticides Control Member

Director, Casco Bay Estuary Partnership

University of Southern Maine, Muskie School of Public Service

Environmental Toxicologist

John Wise, Ph.D

Wise Laboratory CIAET

University of Southern Maine

Terrestrial Entomologist

James Dill, Ph.D, IPM Entomologist

University of Maine Cooperative Extension, Pest Management Office

Lobster Biologist

Carl Wilson

Department of Marine Resources, Marine Fisheries Laboratory

Expert on Lobster Development and Mosquito Insecticides

Michael N. Horst, Ph.D

Mercer University, Macon Georgia

Marine Biologist

Kohl Kanwit, Public Health Bureau Director

Department of Marine Resources

Expert on Pyrethroid Residues in Sediment and Pyrethroid Analytical Chemistry

Lawrence LeBlanc, Ph.D

University of Maine, School of Marine Sciences

Aquatic Entomologist

Leon Tsomides

Maine Department of Environmental Protection, Land and Water Quality

Marine Biologist

Jim Stahlnecker

Maine Department of Environmental Protection, Land and Water Quality

APPENDIX III 2014 Marine Sediment Sampling Results

Montana Analytical Laboratory Results

Table 1. Montana Analytical Laboratory results of analyses of intertidal sediment, collected August 27 to September 10, 2014. (RL = reporting limit, ND = non-detect).

Map Key	Site	Analyte														
		Allethrin (RL=0.20 ppb)	Bifenthrin (RL=0.045 ppb)	cis-Permethrin (RL=0.20 ppb)	Cyfluthrin (RL=0.20 ppb)	Cyhalothrin, total (RL=0.27 ppb)	Cypermethrin (RL=0.20 ppb)	Deltamethrin (RL=0.40 ppb)	Fenpropathrin (RL=0.20 ppb)	Fenvalerate (RL=0.13 ppb)	Phenothrin (RL=2.0 ppb)	PBO (RL=2.0 ppb)	Prallethrin (RL=0.20 ppb)	Resmethrin (RL=2.0 ppb)	Tetramethrin (RL=0.14 ppb)	trans-Permethrin (RL=0.20 ppb)
1	Kittery	ND	0.088	ND	ND	ND	ND	ND	ND	ND	ND	ND	ND	ND	ND	ND
2	Ogunquit	ND	ND	ND	ND	ND	ND	ND	ND	ND	ND	ND	ND	ND	ND	ND
3	Biddeford	ND	0.76	ND	ND	ND	5.0	ND	ND	ND	ND	ND	ND	ND	ND	ND
4	S. Portland	ND	1.0	ND	ND	ND	ND	ND	ND	ND	ND	ND	ND	ND	ND	ND
5	Portland	ND	0.32	ND	ND	ND	ND	ND	ND	ND	ND	ND	ND	ND	ND	ND
6	Yarmouth	ND	0.56	ND	ND	ND	ND	ND	ND	ND	ND	ND	ND	ND	ND	ND
7	Freeport	ND (RL=0.45)*	0.091	ND	ND	ND	ND	ND	ND	ND	ND	ND	ND	ND	ND	ND
8	Brunswick	ND	ND	ND	ND	ND	ND	ND	ND	ND	ND	ND	ND	ND	ND	ND
9	Bath	ND	0.054	ND	ND	ND	ND	ND	ND	ND	ND	ND	ND	ND	ND	ND
9	Bath (duplicate)	ND	0.066	ND	ND	ND	ND	ND	ND	ND	ND	ND	ND	ND	ND	ND
10	Boothbay Harbor	ND (RL=0.45)*	0.26	ND	ND	ND	ND	ND	ND	ND	ND	ND	ND	ND	ND	ND
11	Belfast	ND	ND	ND	ND	ND	ND	ND	ND	ND	ND	ND	ND	ND	ND	ND
12	Rockland	ND	ND	ND	ND	ND	ND	ND	ND	ND	ND	ND	ND	ND	ND	ND
13	Camden	ND	0.060	ND	ND	ND	ND	ND	ND	ND	ND	ND	ND	ND	ND	ND
14	Ellsworth	ND (RL=0.45)*	0.42	ND	ND	ND	ND	ND	ND	ND	ND	ND	ND	ND	ND	ND
15	Blue Hill	ND	0.26	ND	ND	ND	ND	ND	ND	ND	ND	ND	ND	ND	ND	ND
16	Milbridge	ND	ND	ND	ND	ND	ND	ND	ND	ND	ND	ND	ND	ND	ND	ND
17	Addison	ND	ND	ND	ND	ND	ND	ND	ND	ND	ND	ND	ND	ND	ND	ND
18	Jonesboro	ND	ND	ND	ND	ND	ND	ND	ND	ND	ND	ND	ND	ND	ND	ND
19	East Machias	ND	ND	ND	ND	ND	ND	ND	ND	ND	ND	ND	ND	ND	ND	ND
20	Cobscook Bay SP	ND	ND	ND	ND	ND	ND	ND	ND	ND	ND	ND	ND	ND	ND	ND

* Higher reporting limits are due to interference in analyses caused by chemical composition of sediment samples.

Southwest Research Institute Results

Table 2. Southwest Research Institute results of analyses of intertidal sediment, collected between August 27 and September 10, 2014. Reporting limits for the pyrethrins and pyrethroids varied by sample site (0.081-0.20 ppb) due to interference caused by the chemical composition of the sediments. Prallethrin was not reported (NR) due to inability to obtain a valid analysis. (ND = non-detect, NR = not reported)

Map Key	Site	Analyte														
		Allethrin, Total	Bifenthrin	cis-Permethrin	Cyfluthrin, Total	Cyhalothrin, Total	Cypermethrin, Total	Deltamethrin, Total	Fenpropathrin	Fenvalerate	Phenothrin	PBO	Prallethrin	Resmethrin	Tetramethrin	trans-Permethrin
1	Kittery	ND	ND	ND	ND	ND	ND	ND	ND	ND	ND	ND	NR	ND	ND	ND
2	Ogunquit	ND	ND	ND	ND	ND	ND	ND	ND	ND	ND	ND	NR	ND	ND	ND
3	Biddeford	ND	ND	ND	ND	ND	ND	ND	ND	ND	ND	ND	NR	ND	ND	ND
4	S. Portland	ND	ND	ND	ND	ND	ND	ND	ND	ND	ND	ND	NR	ND	ND	ND
5	Portland	ND	ND	ND	ND	ND	ND	ND	ND	ND	ND	ND	NR	ND	ND	ND
6	Yarmouth	ND	ND	ND	ND	ND	ND	ND	ND	ND	ND	ND	NR	ND	ND	ND
7	Freeport	ND	ND	ND	ND	ND	ND	ND	ND	ND	ND	ND	NR	ND	ND	ND
8	Brunswick	ND	ND	ND	ND	ND	ND	ND	ND	ND	ND	ND	NR	ND	ND	ND
9	Bath	ND	ND	ND	ND	ND	ND	ND	ND	ND	ND	ND	NR	ND	ND	ND
9	Bath (duplicate)	ND	ND	ND	ND	ND	ND	ND	ND	ND	ND	ND	NR	ND	ND	ND
10	Boothbay Harbor	ND	ND	ND	ND	ND	ND	ND	ND	ND	ND	ND	NR	ND	ND	ND
11	Belfast	ND	ND	ND	ND	ND	ND	ND	ND	ND	ND	ND	NR	ND	ND	ND
12	Rockland	ND	ND	ND	ND	ND	ND	ND	ND	ND	ND	ND	NR	ND	ND	ND
13	Camden	ND	ND	ND	ND	ND	ND	ND	ND	ND	ND	ND	NR	ND	ND	ND
14	Ellsworth	ND	ND	ND	ND	ND	ND	ND	ND	ND	ND	ND	NR	ND	ND	ND
15	Blue Hill	ND	ND	ND	ND	ND	ND	ND	ND	ND	ND	ND	NR	ND	ND	ND
16	Milbridge	ND	ND	ND	ND	ND	ND	ND	ND	ND	ND	ND	NR	ND	ND	ND
17	Addison	ND	ND	ND	ND	ND	ND	ND	ND	ND	ND	ND	NR	ND	ND	ND
18	Jonesboro	ND	ND	ND	ND	ND	ND	ND	ND	ND	ND	ND	NR	ND	ND	ND
19	East Machias	ND	ND	ND	ND	ND	ND	ND	ND	ND	ND	ND	NR	ND	ND	ND
20	Cobscook Bay SP	ND	ND	ND	ND	ND	ND	ND	ND	ND	ND	ND	NR	ND	ND	ND

Southwest Research Institute Results continued

Table 3. Southwest Research Institute results of analyses of intertidal sediment, collected between August 27 and September 10, 2014. Reporting limits for the pyrethrins and pyrethroids varied by sample site (0.081-0.20 ppb) due to interference caused by the chemical composition of the sediments. Imiprothrin and pyrethrum were not reported (NR) due to inability to obtain a valid analysis. (ND = non-detect, NR = not reported)

Map Key	Site	Analyte										
		Etofenprox	lambda-Cyhalothrin	Imiprothrin*	Pyrethrum*	tau-Fluvalinate , Total	Tefluthrin	Methoprene	Fipronil	Fipronil desulfanyl	Fipronil sulfide	Fipronil sulfone
1	Kittery	ND	ND	NR	NR	ND	ND	ND	ND	ND	ND	ND
2	Ogunquit	ND	ND	NR	NR	ND	ND	ND	ND	ND	ND	ND
3	Biddeford	ND	ND	NR	NR	ND	ND	ND	ND	ND	ND	ND
4	S. Portland	ND	ND	NR	NR	ND	ND	ND	ND	ND	ND	ND
5	Portland	ND	ND	NR	NR	ND	ND	ND	ND	ND	ND	ND
6	Yarmouth	ND	ND	NR	NR	ND	ND	ND	ND	ND	ND	ND
7	Freeport	ND	ND	NR	NR	ND	ND	ND	ND	ND	ND	ND
8	Brunswick	ND	ND	NR	NR	ND	ND	ND	ND	ND	ND	ND
9	Bath	ND	ND	NR	NR	ND	ND	ND	ND	ND	ND	ND
9	Bath (duplicate)	ND	ND	NR	NR	ND	ND	ND	ND	ND	ND	ND
10	Boothbay Harbor	ND	ND	NR	NR	ND	ND	ND	ND	ND	ND	ND
11	Belfast	ND	ND	NR	NR	ND	ND	ND	ND	ND	ND	ND
12	Rockland	ND	ND	NR	NR	ND	ND	ND	ND	ND	ND	ND
13	Camden	ND	ND	NR	NR	ND	ND	ND	ND	ND	ND	ND
14	Ellsworth	ND	ND	NR	NR	ND	ND	ND	ND	ND	ND	ND
15	Blue Hill	ND	ND	NR	NR	ND	ND	ND	ND	ND	ND	ND
16	Milbridge	ND	ND	NR	NR	ND	ND	ND	ND	ND	ND	ND
17	Addison	ND	ND	NR	NR	ND	ND	ND	ND	ND	ND	ND
18	Jonesboro	ND	ND	NR	NR	ND	ND	ND	ND	ND	ND	ND
19	East Machias	ND	ND	NR	NR	ND	ND	ND	ND	ND	ND	ND
20	Cobscook Bay SP	ND	ND	NR	NR	ND	ND	ND	ND	ND	ND	ND

Map 1. 2014 Marine Sediment Sampling Sites

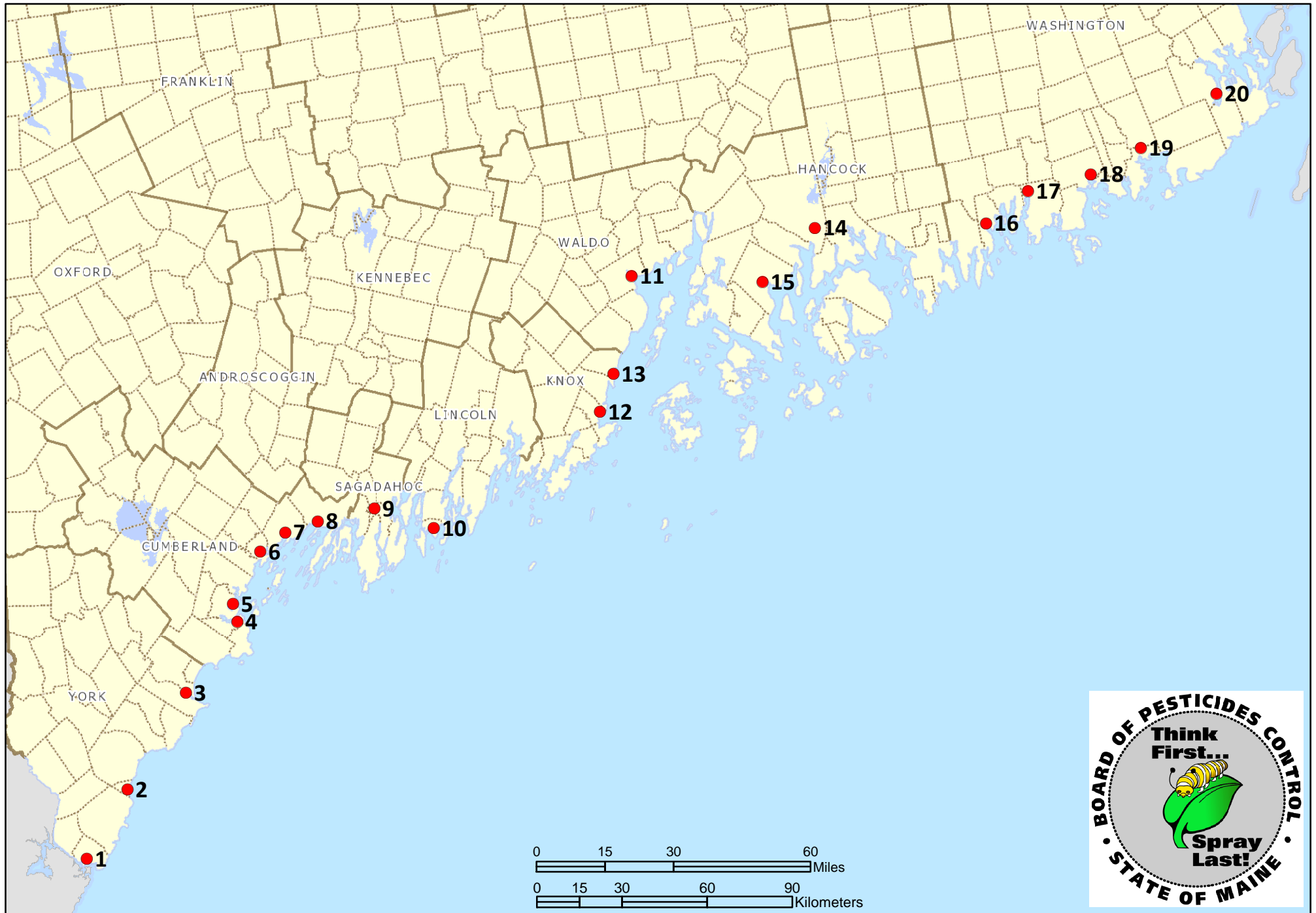

January 30, 2015

Henry Jennings, Director
Maine Board of Pesticide Control
28 State House Station
Augusta, ME 04333

Dear Mr. Jennings:

Enclosed is a copy of Central Maine Power Company's Transmission Right-of-Way Drift Plan for 2015. If you have any questions, I can be reached at 621-3942.

Sincerely,

Nicholas Hahn
Vegetation Management

DRIFT MANAGEMENT PLAN FOR CENTRAL MAINE POWER TRANSMISSION LINE RIGHTS-OF-WAY

During the 2015 calendar year, Central Maine Power Company (CMP) will be treating approximately 10,000 acres as part of our regular vegetation management program. Some of this acreage is comprised of agricultural and industrial uses, and only needs to be patrolled. Integrated vegetation management techniques are employed on the remaining acreage to minimize the use of herbicides.

The first phase of the program requires that a contract crew patrol each right-of-way cutting all hardwood species over 8 feet tall and most of the softwood species. The stumps of trees capable of resprouting are treated with a herbicide. This reduces the amount of foliage that must be treated each cycle. Areas not suitable for foliar herbicide application during the summer are to be entirely cut at this time, and stump treatment to be used where appropriate.

The second phase of this year's program requires that the contract crew patrol each transmission line a second time, treating all remaining tree species capable of growing into the conductors or that block access to the right-of-way. The herbicides are applied with a backpack, hand pressurized spray tank. The tank pressure is low, so the potential for off target movement of the mix is minimized. A contract crew composed of 5 to 8 people will selectively treat the capable species.

A no spray zone is maintained around wells, municipal water supplies or any open water. The buffer zone will vary depending on the topography, a minimum of 25 feet is maintained on all water and a minimum 100-foot buffer is maintained on drinking water supplies. These buffers provide an additional margin of safety.

A low-pressure foliar application technique will be used on the majority of right-of-way scheduled this year. The herbicides and adjuvants, including a drift control agent, are mixed in water at rates of 1/8% - 5%. A hand-pressurized backpack sprayer is used to selectively apply the mix directly to the leaves of the undesirable species. The large droplet size, low tank pressure, and drift control agents, combined with the selective application technique, reduces the potential for drift to a very minimal level. The following is a list of herbicides CMP may use depending on species composition, density and environmental factors:

Garlon 4 Ultra	Arsenal Powerline	Milestone	
Rodeo	Stalker	Aquafact	HY-Grade I

Before a treatment technique or herbicide is selected, a review of the right-of-way is conducted including a list of landowner maintenance agreements, known municipal water supplies, and brush densities. This information helps CMP personnel select the herbicides and determine the mix rates.

A form is given to each crew foreman before the job starts listing all special arrangements, herbicides, and mix rates. All the work is performed by licensed contract

crews. The contract crews will post a sign on the first structure on each side of all public roads stating the date and herbicide used. If herbicides are not applied near the road crossing structure, the first structure where herbicides are used will be posted.

Each town that has a transmission right-of-way scheduled for herbicide work in 2015 will be notified in advance. A landowner maintenance agreement is available to any landowner or municipality objecting to the use of herbicides. The landowner agrees to keep brush to a height less than 10 feet and a CMP inspector looks over each area annually. CMP personnel will notify the staff of the Board of Pesticide Control at the start of the season of general work locations. Daily locations are available at CMP's General Office.

The following list identifies the CMP transmission section numbers and general locations for 2014 scheduled work. Plan and profile maps for each right-of-way are on file at the General Office in Augusta.

2015 CMP TRANSMISSION VEGETATION MANAGEMENT SCHEDULE

<u>Section</u>	<u>Location</u>
7	Jct. L. 41A to Richmond
8	Benton Switch to Shawmut 34kV
10	Shawmut 34KV to Winslow 34kV
14	Bowman St to Puddledock Rd
14A	Jct. L. 14 to Winthrop
16	Edgecomb to Newcastle
18	Newcastle to Damariscotta Mills
37	Jct. L. 77 to Woolwich
44	Lakewood to North Anson
44A	Jct. L 44 to Carrabassett
47	Winslow to Keyes Fiber
50	Gulf Island to Turner Tap
52	Frye to Andover
68	Maxcy's to Mason Station
74	Norway to Woodstock
74A	Jct. L. 74 to Mead Wood Chip
78	Kimball Road to Papoose Pond
86	Bucksport to Belfast 115kV
266	Belfast 115kV to Highland
266A	Jct. L. 266 to Meadow Road
88	Maxcy's 115kV to Augusta E. Side
90	Woodstock to Bethel
90A	Jct. L 90 to Bryant Pond
90B	Jct. L 90 to Locke Mills
90C	Jct. L 90 to Chadbourne Mills
93	Belfast 115KV to Belfast W. Side
96	Woodstock to Newry
102	Elm Street to Gray
103	North Gorham to Prides Corner
111	Quaker Hill to Sanford 115kV
113	Sanford 115KV to Branch Brook
113A	Jct. L. 113 to Sanford I.P.
119	Quaker Hill to Ogunquit
140	Maguire Road to Quaker Hill
140A	Jct. L. 140 to Pratt & Whitney

150 Pleasant Hill to Cape Elizabeth
152 Pleasant Hill to Rigby
West Buxton Hydro to West Buxton
157 115KV
162 Moshers 115KV to So. Groham
163 Louden 115KV to Maguire Road
163A Jct L 163 to West Kennebunk
164 W.F. Wyman to Spring Street 115kV
165 W.F. Wyman to Moshers 115kV
166 Surowiec 115kV to Spring Street 115kV
167 Surowiec 115kV to Moshers 115kV
167A Jct. L. 167 to Prides Corner
168 Bonny Eagle to West Buxton 115kV
169 South Gorham to Westbrook 115kV
172 West Buxton 115kV to Louden 34kV
180 Prides Corner to Elm Street
180A Jct. L. 180 to East Deering
182 W Buxton 115kV to Spring Street 34kV
187 Bonny Eagle to North Gorham
187A Jct. L. 187 to Fort Hill
187B Jct. L. 187 to Shaw Mills Road
189 North Gorham to Raymond 115kV
189A Jct. L. 189 to Portland Pipe Line
193 Spring Street to Vallee Lane
193A Jct 193 to Dunstan
197 Quaker Hill to Three Rivers
198 W.F. Wyman to Elm Street
213 Bowman Street to North Augusta
219 South Gorham to Louden 115kV
220 South Gorham to Louden 115kV
223 South Gorham to W. Buxton 115kV
224 W. Buxton 115kV to Waterboro
225 Waterboro to Sanford 115kV
231 South Gorham to Westbrook 115

233 Westbrook 115 to Spring Street
234 Westbrook 115 to Spring Street
236 Maguire Road to Branch Brook
237 Maguire Road to Sanford 115kV
238 Louden 115KV to Maguire Road
238A L. 238 to Biddeford I.P.

239	Louden to Vallee Lane
243	Rumford IP to Rumford 115 kV
243A	Livermore Falls to Rumford IP
250	Maguire Road to Three Rivers
254	Coopers Mills to Orrington Town Line
270	Rumford 115 KV to Roxbury S/S
272	North Augusta to Augusta East Side
386	South Gorham to Buxton 345
3020	Surowiec to Raven Farm
3021	South Gorham to Maguire Rd.
3022	Maguire Rd. to Three Rivers
3039	WF Wyman Station to Raven Farm
3040	Raven Farm to South Gorham
396BHE	Orrington to Keene Rd
3001BHE	Penobscot River to Chester



PAUL R. LEPAGE
GOVERNOR

STATE OF MAINE
DEPARTMENT OF AGRICULTURE, CONSERVATION AND FORESTRY
BOARD OF PESTICIDES CONTROL
28 STATE HOUSE STATION
AUGUSTA, MAINE 04333-0028

WALTER E. WHITCOMB
COMMISSIONER

HENRY S. JENNINGS
DIRECTOR

February 24, 2015

Ryan Minzner
The Woodlands Club
39 Woods Road
Falmouth, Maine 04105

Re: 2015 Variance Permit

Dear Mr. Minzner:

This letter will serve as The Woodlands Club's Chapter 29 variance permit for your 2015 pest management program. Please bear in mind that this variance permit is dependent upon following the measures outlined in the variance application, particularly Section IX: Method to assure equivalent protection.

We will alert the Board at its March 13, 2015 meeting that the variance permit has been issued. If you have any questions concerning this matter, please feel free to contact me at 287-2731.

Sincerely,

A handwritten signature in cursive script that reads 'Henry Jennings'.

Henry Jennings
Director
Maine Board of Pesticides Control



STATE OF MAINE
DEPARTMENT OF AGRICULTURE, FOOD AND RURAL RESOURCES
BOARD OF PESTICIDES CONTROL
28 STATE HOUSE STATION
AUGUSTA, MAINE 04333-0028

WALTER E. WHITCOMB
COMMISSIONER
HENRY JENNINGS
DIRECTOR

March 13, 2015

Jeffrey M. Taylor
Vegetation Control Service, Inc.
2342 Main Street
Athol, MA 01331

RE: Variance Permit for CMR 01-026, Chapter 29

Dear Mr. Taylor:

On December 13, 2013, the Board authorized the staff to issue multi-year permits for broadcast pesticide applications within 25 feet of water for control of invasive plants provided the applicator has demonstrated knowledge of best management practices for control of the plant, has a multi-year plan for controlling the invasive plants, and has a re-vegetation plan for the site.

By way of this letter, your request for a variance from the 25-foot setback requirement contained in Chapter 29, Section 6 is hereby granted for the treatment of various invasive plants on the Maine Audubon East Point Sanctuary property in Biddeford Pool, Maine. This variance is valid until December 31, 2017. Please bear in mind that your permit is based upon your company adhering to the precautions listed in Section X of your variance application; also, the Board does require that you notify them if there is a change in products to be used.

We will alert the Board at its April 24, 2015 meeting that the variance permit has been issued. If you have any questions concerning this matter, please feel free to contact me at 287-2731.

Sincerely,

Handwritten signature of Henry Jennings

Henry Jennings
Director
Maine Board of Pesticides Control



PAUL R. LEPAGE
GOVERNOR

STATE OF MAINE
DEPARTMENT OF AGRICULTURE, CONSERVATION AND FORESTRY
BOARD OF PESTICIDES CONTROL
28 STATE HOUSE STATION
AUGUSTA, MAINE 04333-0028

12g

WALTER E. WHITCOMB
COMMISSIONER

HENRY JENNINGS
DIRECTOR

April 9, 2015

Jeffrey M. Taylor
General Manager
Vegetation Control Service, Inc.
2 Killeen Street
North Walpole, NH 03609

RE: Variance Permit for CMR 01-026, Chapter 29

Dear Mr. Taylor:

This letter will serve as your variance permit for the control of weeds within the transmission line at the Kibby Wind Power Project for 2015. This permit is valid until December 31, 2015.

In discussing the original permit, the Board of Pesticides Control (BPC) added a caveat which will also hold for this season: because the intent is to spray wetlands when there is no surface water present, and because such areas can quickly become wet during a rain event, the BPC added as a condition to the variance that there be no rain predicted for the area for the 24 hour period following applications. Please bear in mind that your permit is also based upon your company adhering to the precautions listed in Section IX of your variance application.

If you have any questions concerning this matter, please feel free to contact me at 287-2731.

Sincerely,

Henry Jennings
Director
Maine Board of Pesticides Control



PAUL R. LEPAGE
GOVERNOR

STATE OF MAINE
DEPARTMENT OF AGRICULTURE, CONSERVATION AND FORESTRY
BOARD OF PESTICIDES CONTROL
28 STATE HOUSE STATION
AUGUSTA, MAINE 04333-0028

WALTER E. WHITCOMB
COMMISSIONER
HENRY S. JENNINGS
DIRECTOR

February 20, 2015

«Addresses»

RE: Unlawful Insect, Rodent and Weed Control at Health Care Facilities

Dear «Contact»,

Pesticide use inside hospitals or on hospital grounds comes to the forefront every so often, as it did recently for one Maine hospital that was fined by the Maine Board of Pesticides Control (BPC). This incident was especially concerning since the pesticides were applied in patients' rooms by an untrained staff person. Using any product to control, repel or mitigate insects, rodents, weeds or other pests in and around health care facilities is only lawful when done by a properly licensed applicator even if the applicator is a facility employee.

A commercial pesticide applicator license is required whenever pesticides are used in hospitals or other places that are open to the public. Yet, almost every year, the Board hears about hospital employees using pesticides without licensing—sometimes after a complaint has been filed.

People wrongly assume that licensing isn't required for over-the-counter products. Among the commonly used pesticides in these circumstances are insecticides, weed killers and rodent poisons—all products that are widely available over the counter from retail and hardware stores or garden centers. These products are sometimes marketed as "all natural", "organic" or "non-toxic" — all of which promote misconceptions about their regulatory status. No license is required when these products are applied by consumers at their own residences or on their own lawns. However, only a licensed commercial pesticide applicator may use these same products on property open to use by the public.

If you have questions about the laws relating to managing pests at a health care facility, or about how facility staff can obtain a pesticide applicator's license, you may call the BPC office at 287-2731 or visit the BPC website at www.thinkfirstspraylast.org.

Sincerely,

Henry Jennings, Director
Maine Board of Pesticides Control

Enc: – Pertinent excerpts from the Code of Maine Rules.

Maine Board of Pesticides Control

Code of Maine Regulations 10-026 - Chapter 10 - Definitions

01 DEPARTMENT OF AGRICULTURE, CONSERVATION AND FORESTRY

026 BOARD OF PESTICIDES CONTROL

Chapter 10: DEFINITIONS AND TERMS

I. "Commercial applicator" means any person, unless exempted in I(4) hereunder, whether or not the person is a private applicator with respect to some uses, who:

1. Uses or supervises the use of any limited or restricted use pesticide other than as a private applicator; or

2. **Makes or supervises a custom application of a general use pesticide;** or

3. Applies a pesticide in connection with their duties as an official or an employee of federal, state, county, university or local government.

P. **"Custom application" means an application of a pesticide:**

2. To a property open to use by the public;

a. For purposes of this definition, property is deemed to be open to use by the public where its owner, lessee or other lawful occupant operates, maintains or holds the property open or allows access for routine use by members of the public. Persons are considered to be members of the public even though they may pay a fee or other compensation in order to make use of the property or may visit the property for a commercial purpose.

b. Property open to use by the public includes but is not limited to: shopping centers, office and store space routinely open to the public (i.e. rest rooms, self-service areas and display aisles), common areas of apartment buildings, occupied apartments, public pools and water parks, schools and other institutional buildings, public roads, organized recreational facilities, golf courses, campgrounds, parks, parking lots, ornamental and turf areas around condominiums, apartment buildings, stores malls and retail areas of greenhouses and nurseries if the public is allowed access before the pesticide restricted-entry or re-entry interval elapses.